

ACE OF SPADES 125

OUTLAW 125

Ed. 09-2019



ACE OF SPADES



OUTLAW



Catalogo ricambi
Spare parts catalog
Catalogue pieces de rechange
Ersatzteilkatalog
Catalogo piezas de repuestos



INFORMAZIONI GENERALI

Il presente catalogo serve per richiedere con esattezza le parti di ricambio
Nelle ordinazioni indicare:

- 1) il numero di codice dei particolari seguito dalla descrizione;
- 2) il colore per i pezzi verniciati o comunque colorati;
- 3) il numero di matricola del motociclo, stampigliato sul canotto di sterzo.

Le indicazioni destra e sinistra si riferiscono ai lati del veicolo rispetto al senso di marcia;

GENERAL INFORMATION

The present spare parts list enables one to order exactly the right spare parts.
When ordering specify:

- 1) the part's code number followed by its description;
- 2) indicate colour for painted or coloured parts;
- 3) the motorcycle's serial number, stamped on the steering head.

References to right and left apply to the vehicle in terms of its direction of movement.

INFORMATIONS GENERALES

Ce catalogue permet de commander correctement les pièces de rechange.
Les commandes doivent être passées en indiquant:

- 1) le numéro de code des pièces détachées suivi de leur description;
- 2) le couleur des pièces peintes ou colorés;
- 3) le matricule de la moto, estampillé sur la tige du guidon.

Droite et gauche sont les côtés du véhicule par rapport au sens de la marche.

ALLGEMEINE HINWEISE

Dieser Ersatzteilkatalog dient zur genauen Angabe der Teile bei
Ersatzteilbestellungen.

Bei Ersatzbestellung ist folgendes anzugeben:

- 1) Die Bestellnummer der Ersatzteile mit der entsprechenden Beschreibung;
- 2) Farbe für lackierte und farbige Teile angeben;
- 3) Die Sseriennummer des Motorrads, die am Lenkrohr eingepreßt ist.

Die Angaben rechts und links beziehen sich auf das Fahrzeug in Fahrrichtung.

INFORMACIONES GENERALES

El presente catálogo sirve para pedir con exactitud las partes de recambio.
En los pedidos se debe indicar:

- 1) el número de código de la parte y a continuación la descripción;
- 2) el color para las piezas barnizadas o coloreadas;
- 3) el número de matrícula de la motocicleta, estampado en el tubo de dirección.

Las indicaciones derecha e izquierda se refieren a los lados del vehículo respecto del sentido de marcha.

Dati indicativi soggetti a modifiche senza impegno di preavviso.

All data are subject to modification without prior notice.

Données indicatif sujet au modifications sans obligation de préavis.

Anderungen Vorbehalten.

Datos indicativos sujetos a modificaciones sin compromiso de preaviso.

NOTE - LIST - NOTES - NOTE - NOTAS:

AUS : Australia, Australia, Australie, Australien, Australia

CDN : Canada, Canada, Canada, Kanada, Canadá

IT : Italia, Italy, Italie, Italien, Italia

JAP : Giappone, Japan, Japon, Japan, Japón

USA : Stati Uniti d'America, United States of America, Etats Units d'Amerique,
Vereingte Staaten von Amerika, Estados Unidos

N° DI MATRICOLA INIZIALE - INITIAL SERIAL NUMBER - MATRICULE INITIAL - BEGINNTESEIENNUMMER - MATRICULA INICIAL	
MODELLO - MODEL MODELE - MODELL MODELO	MATRICOLA - SERIAL NUMBER MATRICULE - SERIENNUMMER MATRICULA
ACE OF SPADES	ZN0B700AAKV000001
OUTLAW	ZN0B700AAKV000001



INDICE – INDEX – INDEX – INHALTSVERZEICHNIS – INDICE

**ACE OF SPADES 125
OUTLAW 125**

Tavola Drawing Table Bild Tabla	Denominazione	Description	Designation	Bezeichnung	Denominacion	Pagina Page Seite Paja
1	ATTREZZI DI ASSISTENZA, MANUALI E DOTAZIONI	SERVICE TOOLS, MANUALS AND EQUIPMENT	OUTILS D'ASSISTANCE, MANUELS ET EQUIPEMENT	HILFAUSRUSTUNG, HANDBUCH UND DOTIERUNG	HERRAMIENTAS DE ASISTENCIA, MANUALES Y EQUIPAMIENTO	13
2	CILINDRO, PISTONE	CYLINDER, PISTON	CYLINDRE, PISTON	ZYLINDER, KOLBEN	CILINDRO, PISTON	15
3	TESTA CILINDRO	CYLINDER HEAD	CULASSE	ZYLINDERKOPF	CULATA	17
4	COPERCHIO VALVOLE	VALVE COVER	COUVERCLE CULASSE	ZYLINDERKOPFDECKEL	TAPA CULATA	19
5	MANOVELLISMO	CRANKSHAFT	VILEBREQUIN	KURBELWELLE	CIGÜEÑAL	21
6	DISTRIBUZIONE	VALVE TIMING	DISTRIBUTION	VENTILSTEUERUNG	DISTRIBUCION	23
7	LUBRIFICAZIONE	OIL PUMP	PUMPE HUILE	MOTORSCHMIERUNG	LUBRICACION	25
8	COPERCHIO CARTER SINISTRO	LEFT CRANKCASE COVER	COUVERCLES CARTER GAUCHE	GEHAUSEDECKEL LINKS	TAPAS BANCADA IZQUIERDA	27
9	SEMICARTER SINISTRO	LEFT HALF CRANKCASE	CARTER GAUCHE	GEHAUSEDECKEL LINKS	BANCADA IZQUIERDA	29
10	SEMICARTER DESTRO	RIGHT HALF CRANKCASE	CARTER DROIT	GEHAUSEDECKEL RECHTS	BANCADA DERECHO	31
11	FRIZIONE	CLUTCH	EMBAYAGE	KUPPLUNG	EMBRAGUE	33
12	COMANDO CAMBIO	GEARSHIFT MECHANISM	COMMANDE DE VITESSE	GANGSCHALTUNG	MANDO CAMBIO	35
13	PARTE ELETTRICA	IGNITION SISTEM	PARTIES ELECTRIQUE	ELEKTRISCHE TEILE	PARTE ELECTRICA	37
14	AVVIAMENTO	STARTING	DEMARRAGE	ANLASSER	ARRANQUE	39
15	CORPO FARFALLATO	THROTTLE BODY	CORP PAPILLON	DROSSELKLAPPENKÖRPER	CUERPO OSCILANTE	41
16	FILTRO ARIA	AIR FILTER	FILTRE AIRE	LUFTFILTER	FILTRO DE AIRE	43
17	IMPIANTO DI RAFFREDAMENTO	COOLING SYSTEM	INSTALLATION RAFROIDISSEMENT	SCHMIERUNGSSYSTEM	EQUIPO DE ENFRIAMIENTO	45
18	SERBATOIO CARBURANTE	FUEL TANK	RESERVOIR CARBURANT	KRAFTSTOFFBEHALTER	DEPOSITO GASOLINA	49
19	PANNELLI, PARAFANGHI, SELLA	PANEL, FENDERS, SEAT	PANNEAU, GARDE-BOUES, SIEGE	STREIFEN, KOTFLUGEL, SATTEL	PANELO, GUARDABARROS, SILLIN	51
20	TELAIO, PEDANE	FRAME, FOOT RESTS	CADRE, REPOSE PIEDS	RAHMEN, FUSSBRETT	BASTIDOR, REPOSAPIES	53
20A	PEDANE E MANIGLIE PASSEGGERO	PASSENGER FOOT RESTS AND HANDLES	REPOSE PIEDS ET POIGNÉE PASSAGER	BEIFAHRRERFUßRASTE UND GRIFF	REPOSAPIES Y MANILLA ACOMPAÑANTE	57
21	MANUBRIO E COMANDI	HANDLEBAR AND CONTROLS	GUIDON ET COMMANDES	LENKER UND STEUERORGANE	MANILLAR Y MANDOS	59
22	SOSPENSIONE ANTERIORE	FRONT FORK ASSEMBLY	SUSPENSION AVANT	VORDETELESKOPGABEL	SUSPENSION DELANTERA	61
22A	FORCELLA SINISTRA	LEFT FORK	FOURCHE GAUCHE	GABEL, LINKS	HORQUILLA IZQUIERDA	63
22B	FORCELLA DESTRA	RIGHT FORK	FOURCHE DROIT	GABEL, RECHTS	HORQUILLA DERECHA	65
23	FORCELLONE E AMMORTIZZATORE POSTERIORE	REAR SWING ARM AND SUSPENSION	FOURCHE AT SUSPENSION ARRIERE	HINTERHAUFHANGUNG	HORQUILLA YSUSPENSION TRASERA	67
24	RUOTA ANTERIORE	FRONT WHEEL	ROUE AVANT	VORTERRAD	RUEDA DELANTERA	69
25	RUOTA POSTERIORE	REAR WHEEL	ROUE ARRIERE	HINTERRAD	RUEDA TRASERA	71
26	FRENO IDRAULICO ANTERIORE	FRONT HYDRAULIC BRAKE	FREIN HYDRAULIQUE AVANT	VORDERBREMSE	FRENO HIDRAULICO DELANTERO	73
27	FRENO IDRAULICO POSTERIORE	REAR HYDRAULIC BRAKE	FREIN HYDRAULIQUE ARRIERE	HINTERBREMSE	FRENO HIDRAULICO TRASERO	75
28	SCARICO	EXHAUST SYSTEM	TUYAU D'ECHAPPEMENT	AUSPUFFROHR	TUBO DE ESCAPE	77



INDICE – INDEX – INDEX – INHALTSVERZEICHNIS – INDICE

ACE OF SPADES 125
OUTLAW 125

Tavola Drawing Table Bild Tabla	Denominazione	Description	Designation	Bezeichnung	Denominacion	Pagina Page Page Seite Paja
29	STRUMENTO DIGITALE	DIGITAL INSTRUMENT	INSTRUMENT DIGITAL	DIGITAL TACHOMETER	INSTRUMENTO DIGITAL	79
30	GRUPPO CAVI, PARTI ELETTRICHE	MAIN WIRING HARNESS	CABLES PRINCIPAL, PARTIES ELECTR.	KABEL, ELEKTRISCHE KOMPONENTE	GRUPO CABLES, PARTES ELECTRICAS	81
31	DECALCOMANIE (ACE OF SPADES)	TRANSFER (ACE OF SPADES)	DECALCOMANIE (ACE OF SPADES)	ABZIEHBILD (ACE OF SPADES)	CALCOMANIA (ACE OF SPADES)	85
31A	DECALCOMANIE (OUTLAW)	TRANSFER (OUTLAW)	DECALCOMANIE (OUTLAW)	ABZIEHBILD (OUTLAW)	CALCOMANIA (OUTLAW)	89

Tavola - Drawing - Table - Bild - Tabla

1

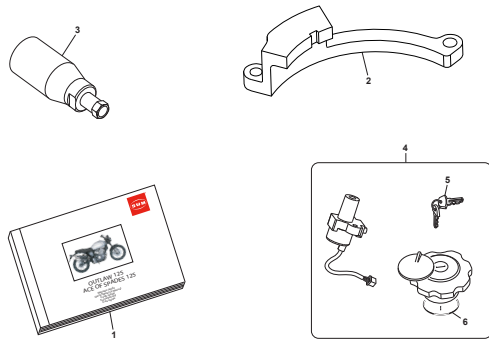

Pagina - Page - Page - Seite - Paja

12

Tavola - Drawing - Table - Bild - Tabla

2

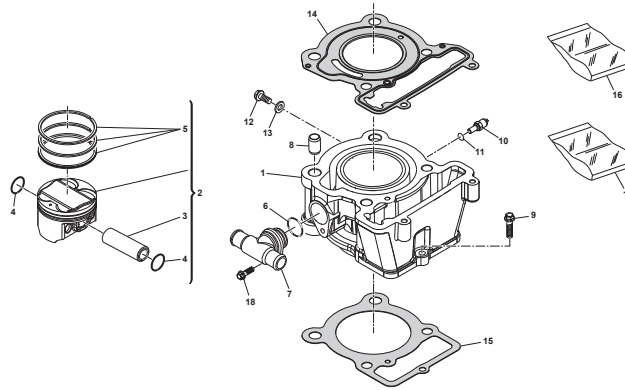

Pagina - Page - Page - Seite - Paja

14

Tavola - Drawing - Table - Bild - Tabla

3

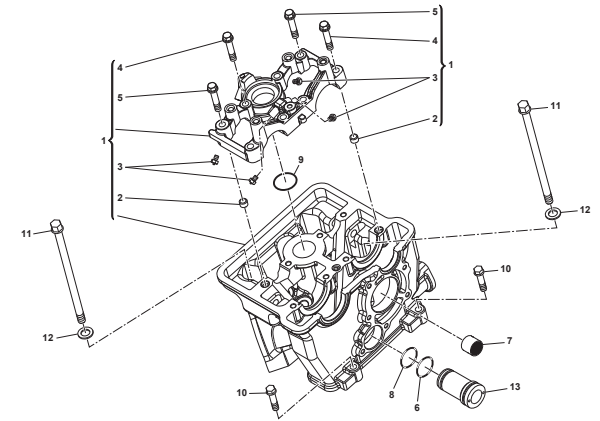

Pagina - Page - Page - Seite - Paja

16

Tavola - Drawing - Table - Bild - Tabla

4

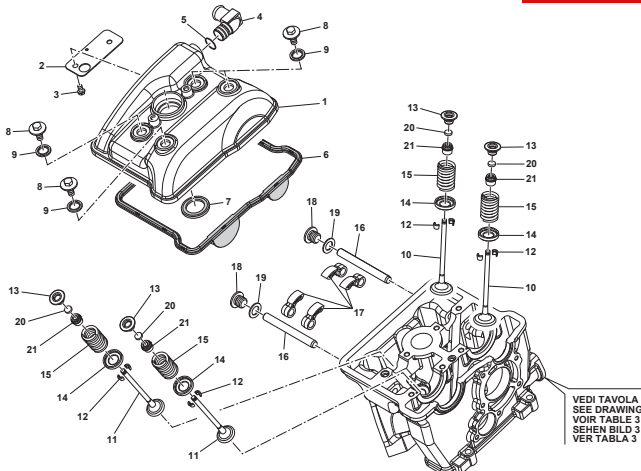

Pagina - Page - Page - Seite - Paja

18

Tavola - Drawing - Table - Bild - Tabla

5

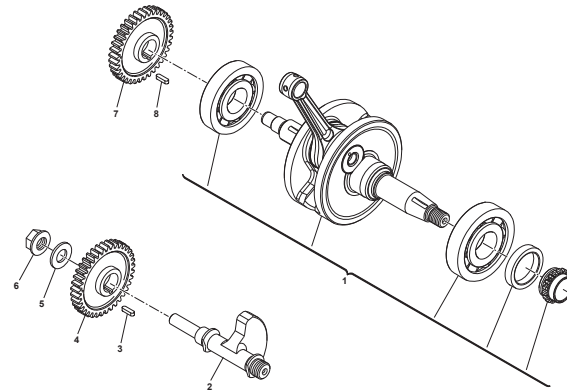

Pagina - Page - Page - Seite - Paja

20

Tavola - Drawing - Table - Bild - Tabla

6

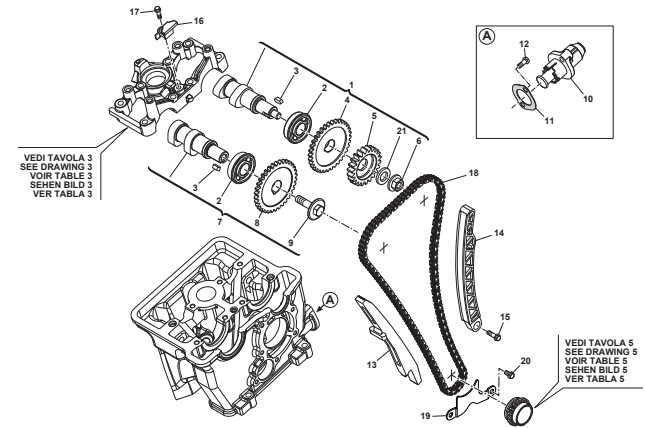

Pagina - Page - Page - Seite - Paja

22

Tavola - Drawing - Table - Bild - Tabla

7

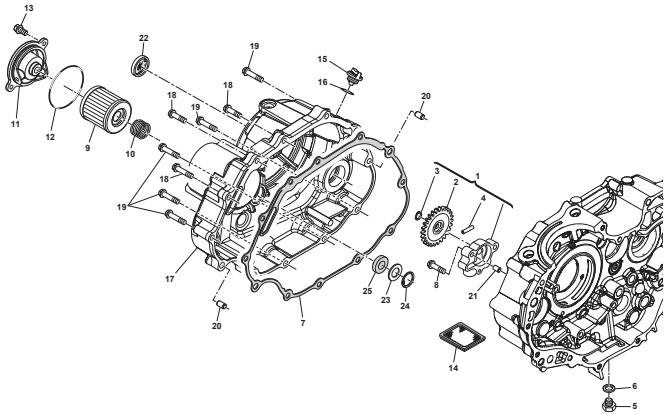

Pagina - Page - Page - Seite - Paja

24

Tavola - Drawing - Table - Bild - Tabla

8

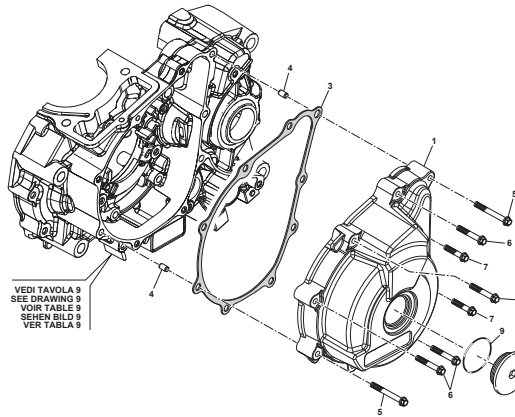

Pagina - Page - Page - Seite - Paja

26

Tavola - Drawing - Table - Bild - Tabla

9

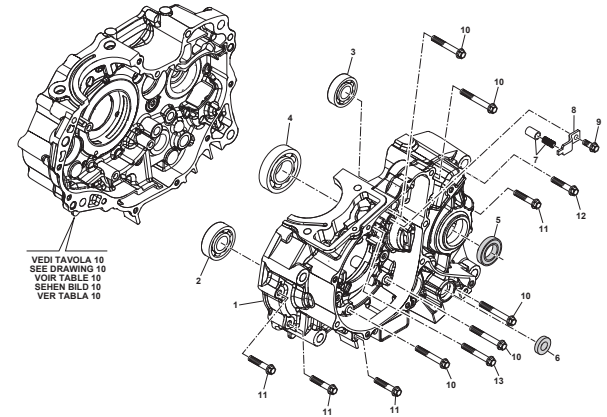

Pagina - Page - Page - Seite - Paja

28

Tavola - Drawing - Table - Bild - Tabla

10

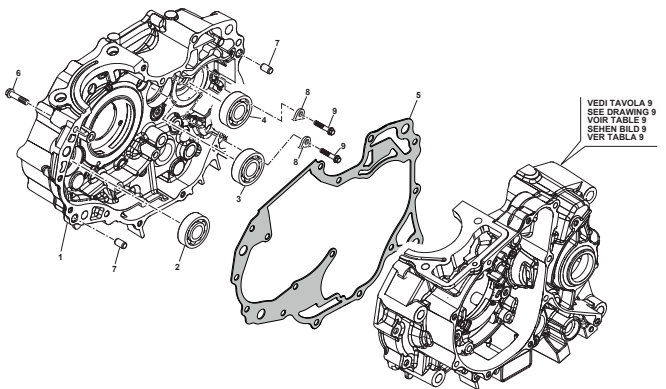

Pagina - Page - Page - Seite - Paja

30

Tavola - Drawing - Table - Bild - Tabla

11

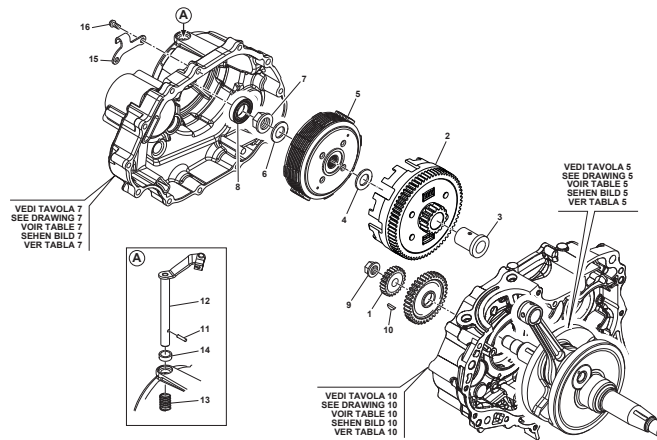

Pagina - Page - Page - Seite - Paja

32

Tavola - Drawing - Table - Bild - Tabla

12

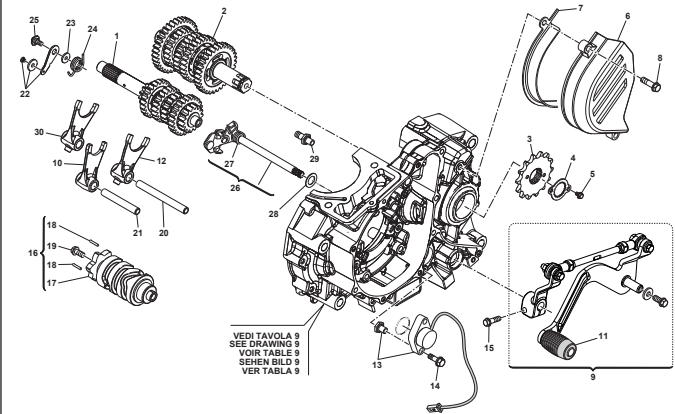

Pagina - Page - Page - Seite - Paja

34

Tavola - Drawing - Table - Bild - Tabla

13

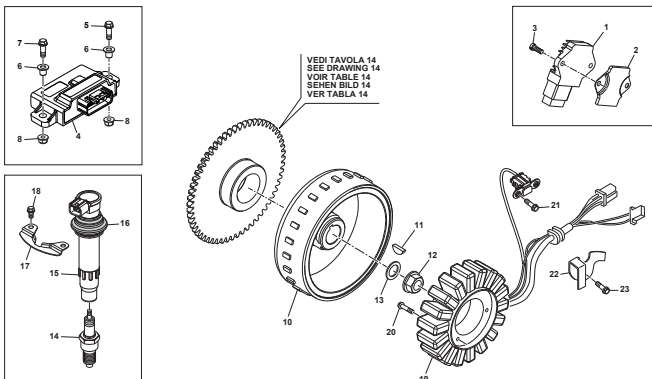

Pagina - Page - Page - Seite - Paja

36

Tavola - Drawing - Table - Bild - Tabla

14

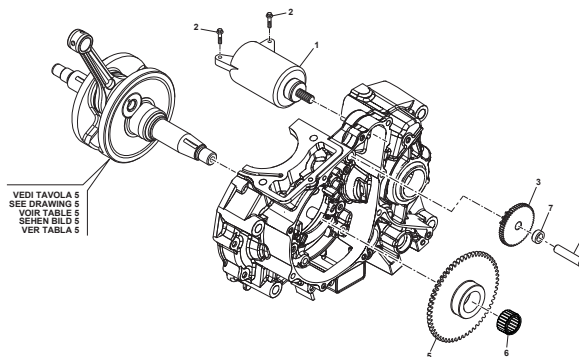

Pagina - Page - Page - Seite - Paja

38

Tavola - Drawing - Table - Bild - Tabla

15

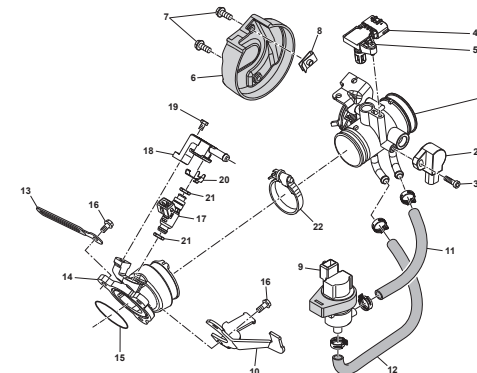

Pagina - Page - Page - Seite - Paja

40

Tavola - Drawing - Table - Bild - Tabla

16

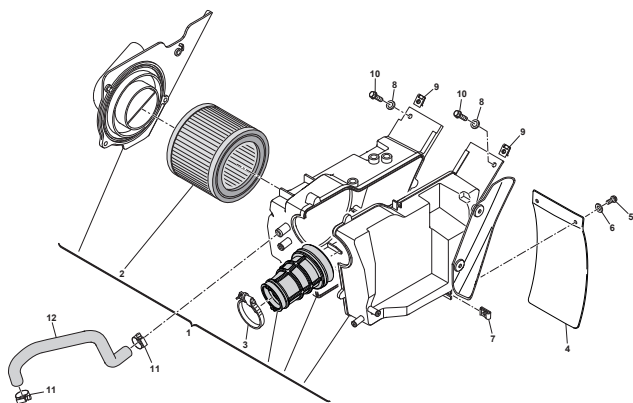

Pagina - Page - Page - Seite - Paja

42

Tavola - Drawing - Table - Bild - Tabla

17

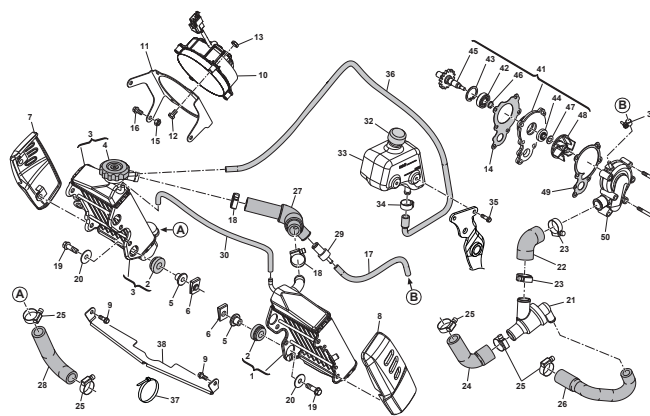

Pagina - Page - Page - Seite - Paja

44

Tavola - Drawing - Table - Bild - Tabla

18

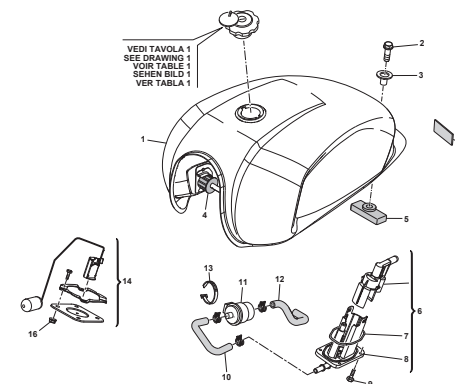

Pagina - Page - Page - Seite - Paja

48

Tavola - Drawing - Table - Bild - Tabla

19

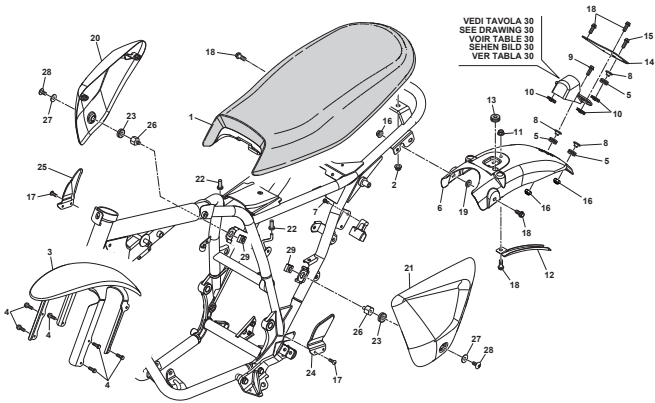

Pagina - Page - Page - Seite - Paja

50

Tavola - Drawing - Table - Bild - Tabla

20

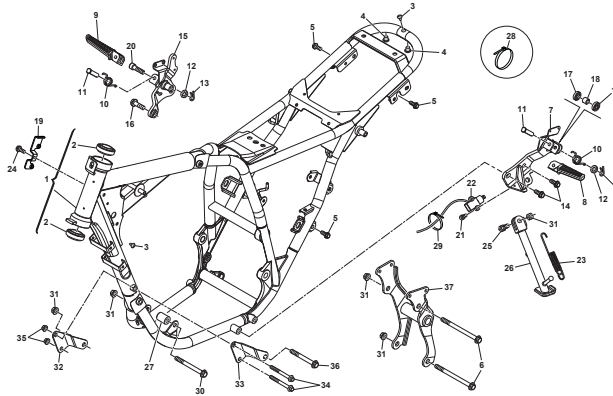

Pagina - Page - Page - Seite - Paja

52

Tavola - Drawing - Table - Bild - Tabla

20A

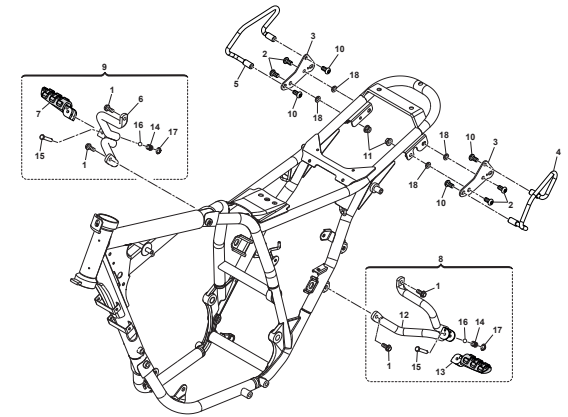

Pagina - Page - Page - Seite - Paja

56

Tavola - Drawing - Table - Bild - Tabla

21

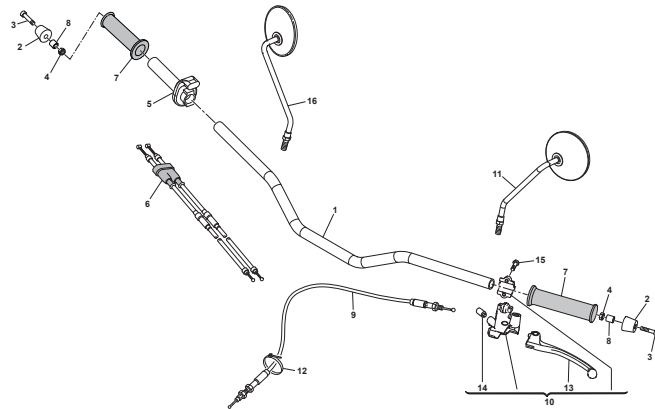

Pagina - Page - Page - Seite - Paja

58

Tavola - Drawing - Table - Bild - Tabla

22

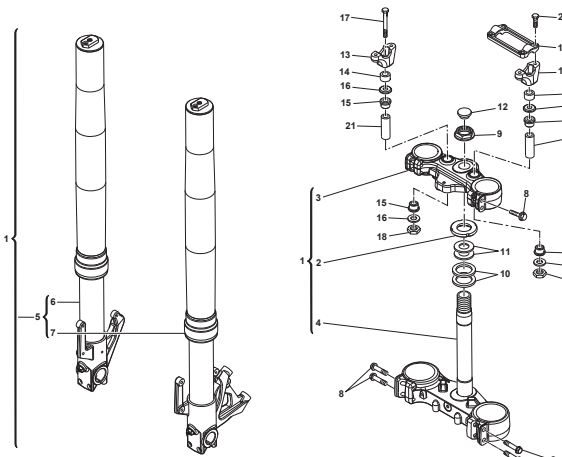

Pagina - Page - Page - Seite - Paja

60

Tavola - Drawing - Table - Bild - Tabla

22A

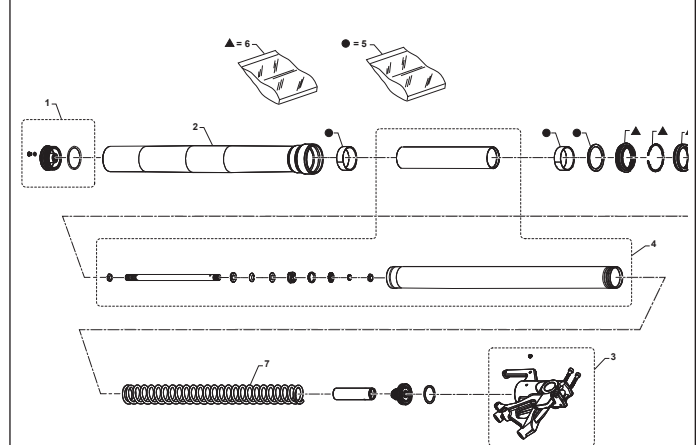

Pagina - Page - Page - Seite - Paja

62



Tavola - Drawing - Table - Bild - Tabla

22B

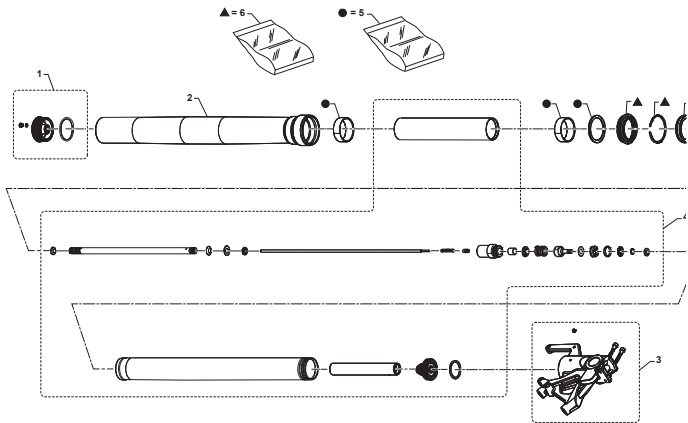

Pagina - Page - Page - Seite - Paja

64

Tavola - Drawing - Table - Bild - Tabla

23

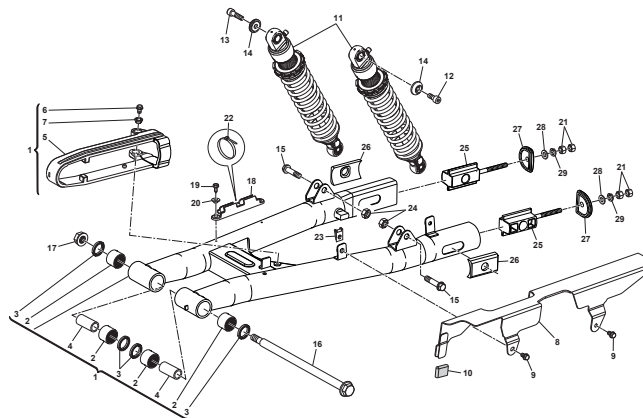

Pagina - Page - Page - Seite - Paja

66

Tavola - Drawing - Table - Bild - Tabla

24

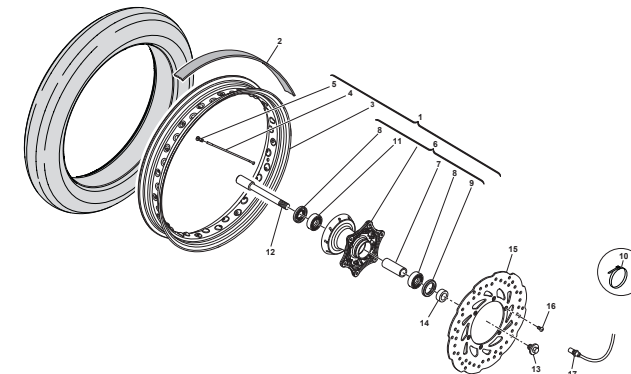

Pagina - Page - Page - Seite - Paja

68

Tavola - Drawing - Table - Bild - Tabla

25

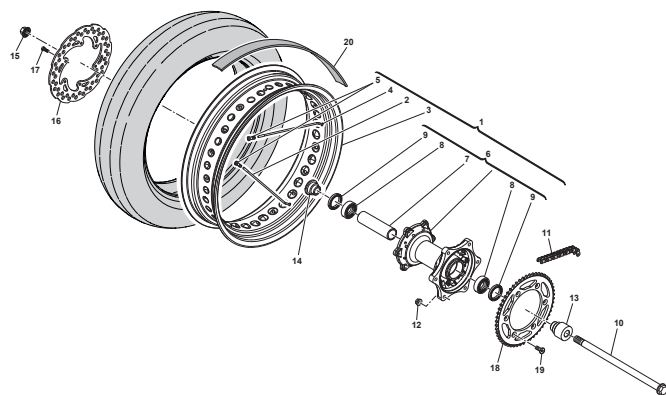

Pagina - Page - Page - Seite - Paja

70

Tavola - Drawing - Table - Bild - Tabla

26

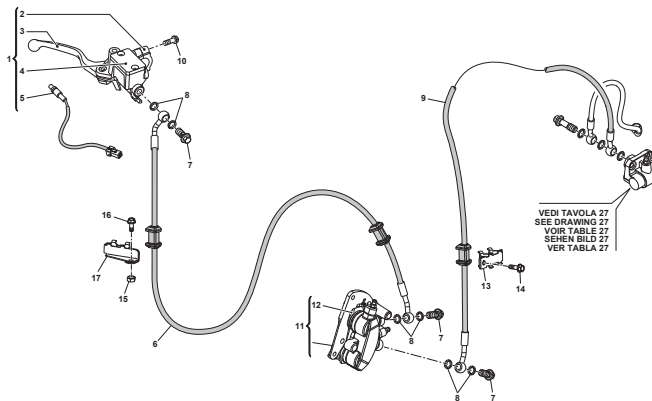

Pagina - Page - Page - Seite - Paja

72

Tavola - Drawing - Table - Bild - Tabla

27

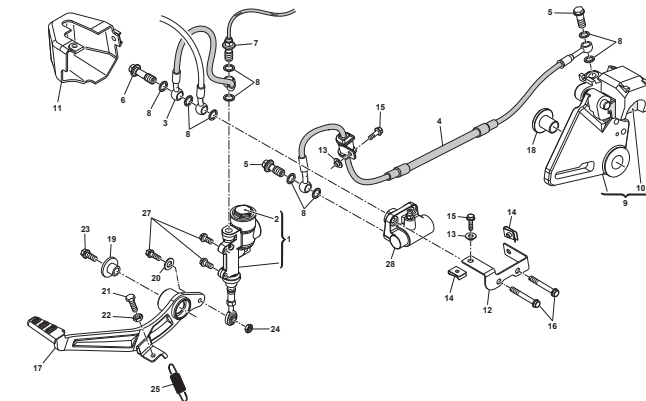

Pagina - Page - Page - Seite - Paja

74

Tavola - Drawing - Table - Bild - Tabla

28

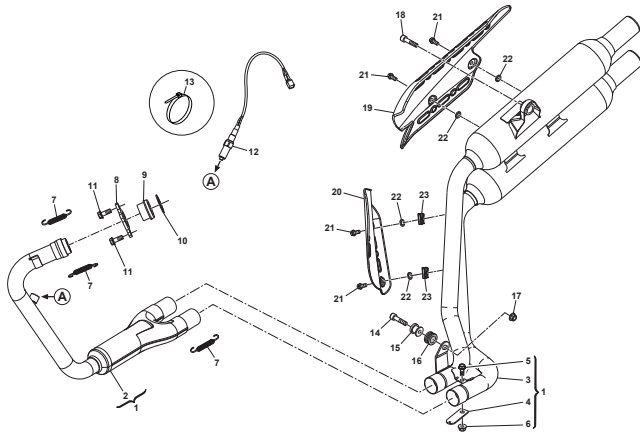

Pagina - Page - Page - Seite - Paja

76

Tavola - Drawing - Table - Bild - Tabla

29

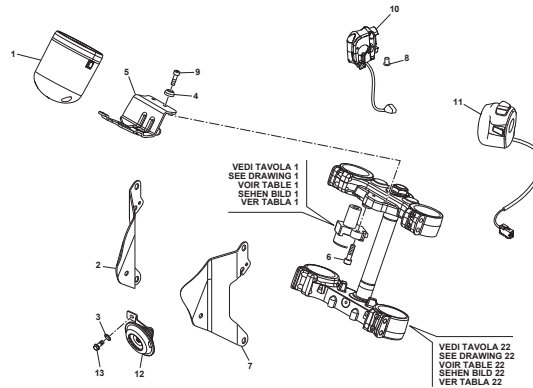

Pagina - Page - Page - Seite - Paja

78

Tavola - Drawing - Table - Bild - Tabla

30

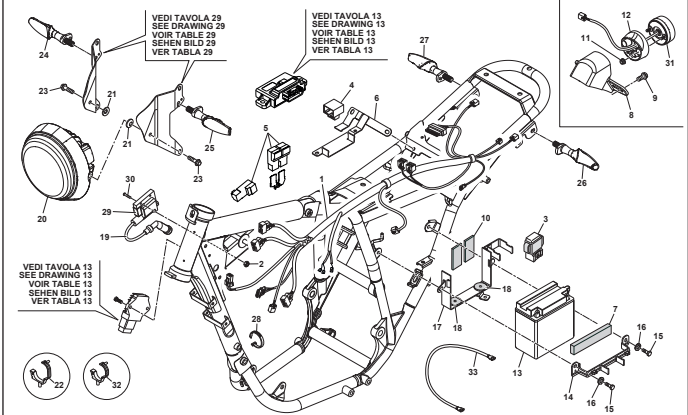

Pagina - Page - Page - Seite - Paja

80

Tavola - Drawing - Table - Bild - Tabla

31

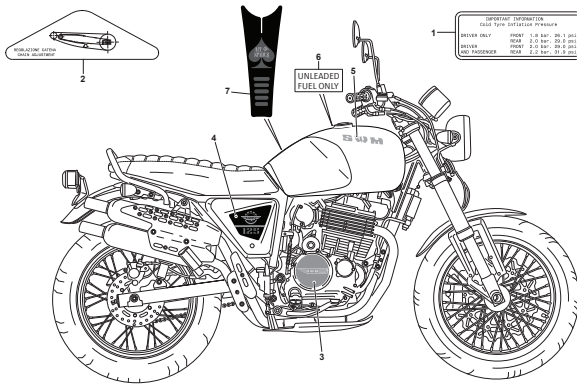

Pagina - Page - Page - Seite - Paja

82

Tavola - Drawing - Table - Bild - Tabla

31A

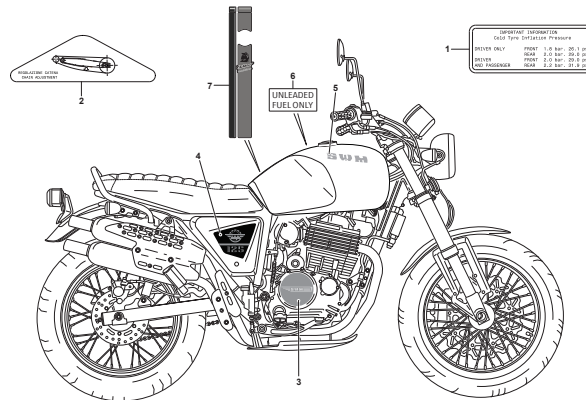

Pagina - Page - Page - Seite - Paja

84



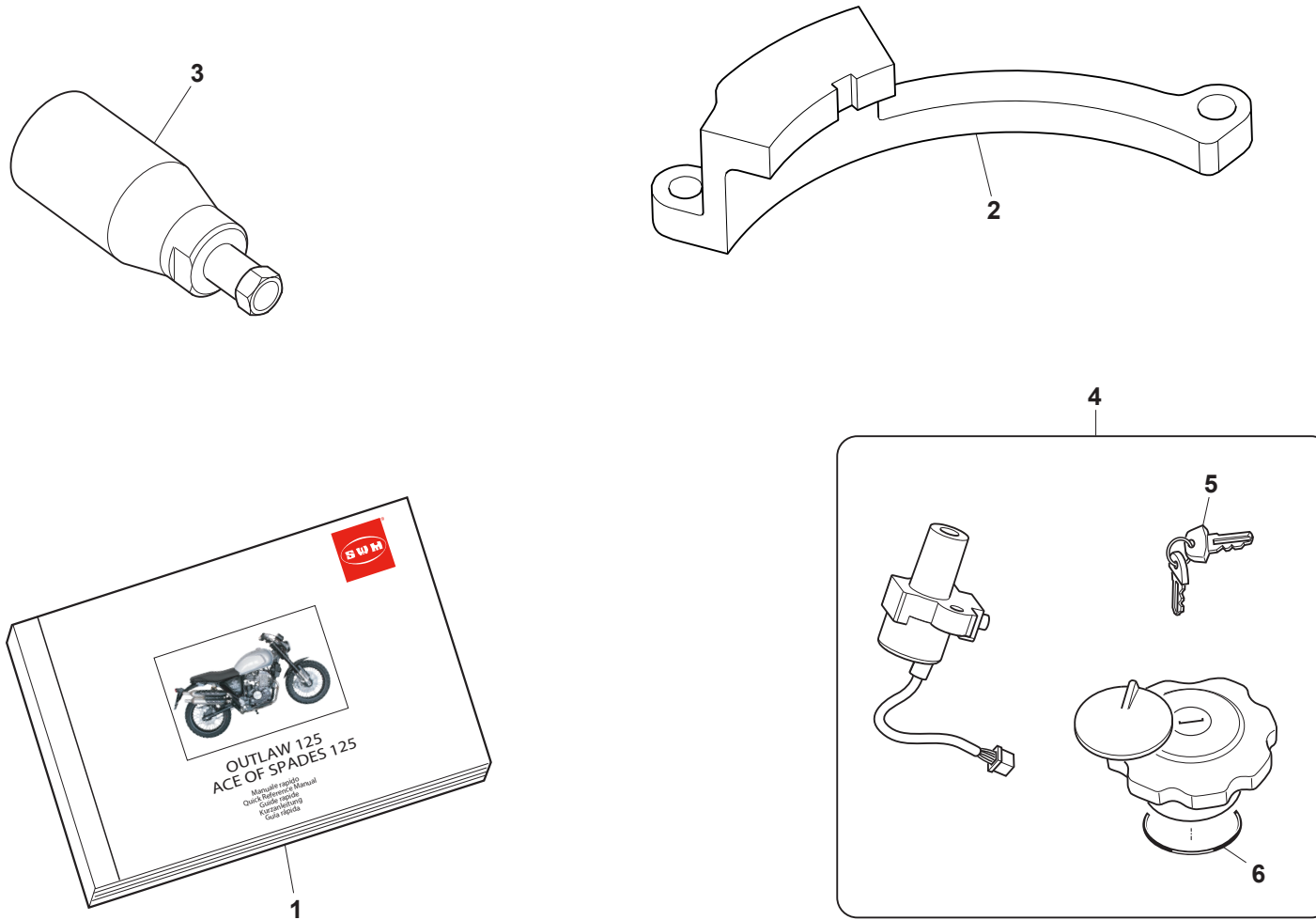



Note Notes Marke Notas	Pos. No. Index Pos.	N. Cod. Code No. Nr. Code Code Nr N. Cod.	Q.tà Q.ty M.ge C.ad	DENOMINAZIONE	NAME	DESIGNATION	BESHREIBUNG	DENOMINACION
	1	A000P03487	1	QUICK MANUAL	QUICK MANUAL	GUIDE RAPIDE	QUICK MANUAL	QUICK MANUAL
	2	M000P02026	1	ATTREZZO FERMO VOLANO PMS	TDC FLYWHEEL RETAINING TOOL	OUTIL D'ARRET VOLANT AU P.M.H.	KLEMMWERKZEUG SICHERUNGS SCHWUNGRAD AM OT	HERRAMIENTA DE RETENCION VOLANTE EN EL PMS
	3	M000P02025	1	ESTRATTORE VOLANO	FLYWHEEL PULLER	EXTRACTEUR VOLANT	ABZIEHER SCHWUNGRAD	EXTRACTOR VOLANTE
	4	F000P01493	1	KIT SERRATURE	LOCK KIT	KIT SERRURES	SATZ SCHLÖSSER	KIT CERRADURAS
	5	F000P01565	1	CHIAVE GREZZA	KEY BLANK	CLÉ BRUTE	ROHSHLÜSSEL	LLAVE EN BRUTO
	6	F000P01566	1	GUARNIZIONE TAPPO	GASKET CAP	JOINT BOUCHON	DICHTUNG DECKEL	JUNTA TAPON

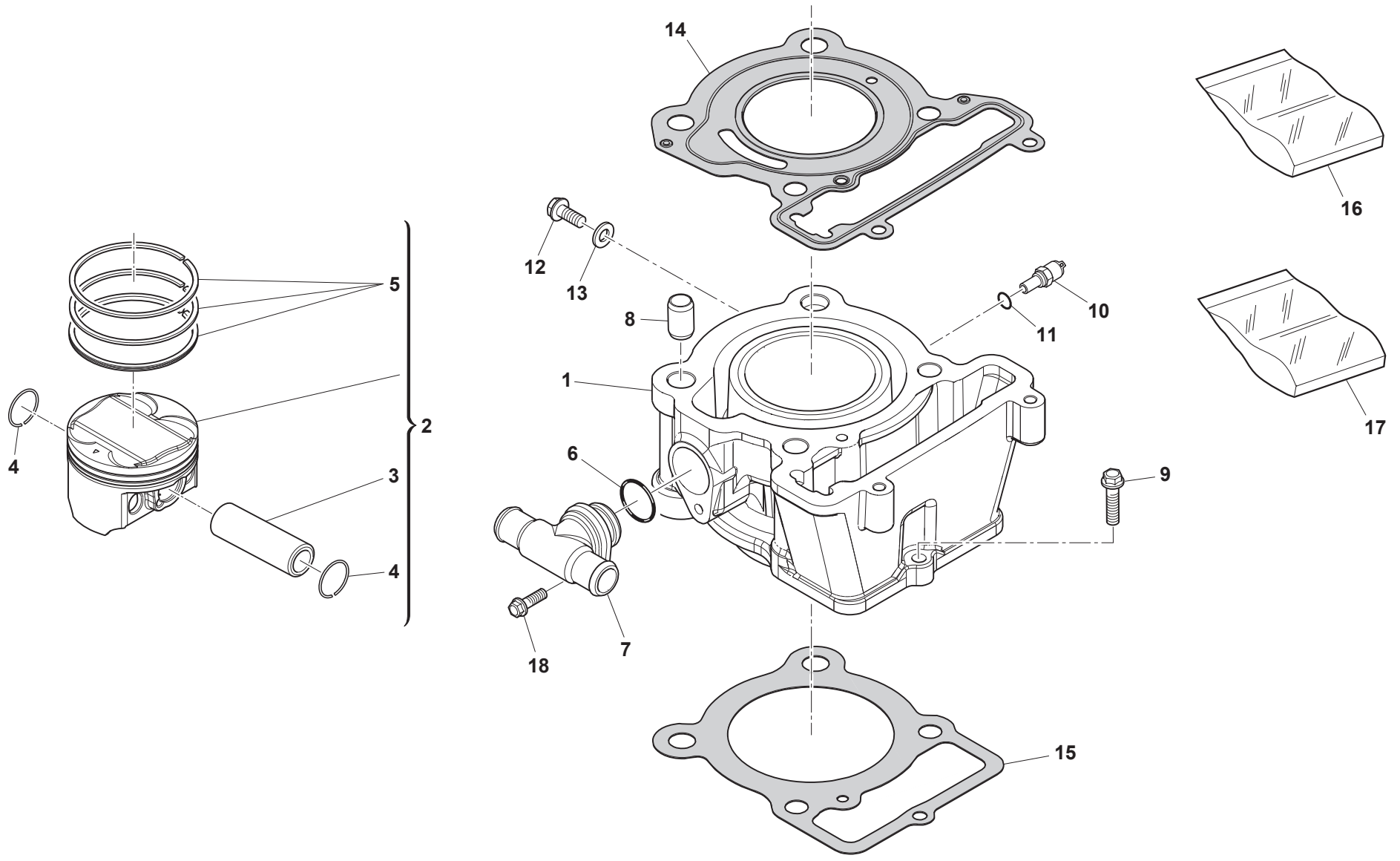



Note Notes Marke Notas	Pos. No. Index Pos.	N. Cod. Code No. Nr. Code Code Nr N. Cod.	Q.tà Q.ty Q.te M.ge C.ad	DENOMINAZIONE	NAME	DESIGNATION	BESHREIBUNG	DENOMINACION
	1	27010707	1	CILINDRO MOTORE	CYLINDER	CYLINDRE	ZYLINDER	CILINDRO
	2	76220001	1	ASSIEME PISTONE COMPLETO	COMPLETE PISTON ASSY	PISTON COMPLET	ZUSAMMENBAU KOLBEN KOMPLETT	CONJUNTO PISTÓN COMPLETO
	3	21040047	1	SPINOTTO	PISTON PIN	GOUJON	KOLBENBOLZEN	EJE DE PISTON
	4	72080133	2	ANELLO RITEGNO SPINOTTO	PISTON PIN RETAINING RING	BAGUE DE RETENUE GOUJON	RÜCKHALTERING KOLBENBOLZEN	ANILLO DE RETENCION EJE DE PISTON
	5	21030599	1	KIT SEGMENTI PISTONE	PISTON RING KIT	KIT SEGMENTS PISTON	SATZ KOLBENRINGE	KIT SEGMENTOS PISTÓN
	6	72150236	1	ANELLO OR	O-RING	JOINT TORIQUE	O-RING	JUNTA TORICA
	7	17050010	1	RACCORDO	UNION	RACCORD	ANSCHLUSS	RACOR
	8	72060169	4	BUSSOLA Ø12x10	DOWEL PIN Ø12x10	DOUILLE Ø12x10	BUCHSE Ø12x10	CASQUILLO Ø12x10
	9	72012194	1	VITE TCEI M6x23	SCREW TCEI M6x23	VIS TCEI M6x23	SCHRAUBE TCEI M6x23	TORNILLO TCEI M6x23
	10	8000H3649	1	SENSORE TEMPERATURA ACQUA	WATER TEMPERATURE SENSOR	CAPTEUR DE TEMPÉRATURE EAU	WASSERTEMPERATURSENSOR	SENSOR TEMPERATURA AGUA
	11	8A0023108	1	ANELLO OR	O-RING	JOINT TORIQUE	O-RING	JUNTA TORICA
	12	72010155	1	VITE TEF M6x12	FLANGED EXAGON HEAD SCREW M6x12	BOULON DE BRIDE M6x12	FLANSCHENSCHRAUBE M6x12	TORNILLO DE REBORDE M6x12
	13	72040157	1	ROSETTA IN RAME	COPPER WASHER	RONDELLE	UNTERLEGSCHNEIBE	ARANDELA
	14	72130612	1	GUARNIZIONE TESTA	HEAD GASKET	JOINT CULASSE	ZYLINDERKOPFDICHTUNG	JUNTA CULATA
	15	72130632	1	GUARNIZIONE CILINDRO	CYLINDER GASKET	JOINT CYLINDRE	ZYLINDERDICHTUNG	JUNTA CILINDRO
	16	M000A01635	1	KIT GUARNIZIONI MOTORE	ENGINE GASKET KIT	KIT JOINTS MOTEUR	SATZ MOTORDICHTUNGEN	KIT JUNTAS MOTOR
	17	M000A01636	1	KIT ANELLI DI TENUTA MOTORE	ENGINE SEALING RING KIT	KIT BAGUES D'ÉTANCHÉITÉ MOTEUR	SATZ DICHTUNGSRINGE MOTOR	KIT ANILLOS DE ESTANQUEIDAD MOTOR
	18	72010157	1	VITE TEF M6x16	FLANGED EXAGON HEAD SCREW M6x16	BOULON DE BRIDE M6x16	FLANSCHENSCHRAUBE M6x16	TORNILLO DE REBORDE M6x16

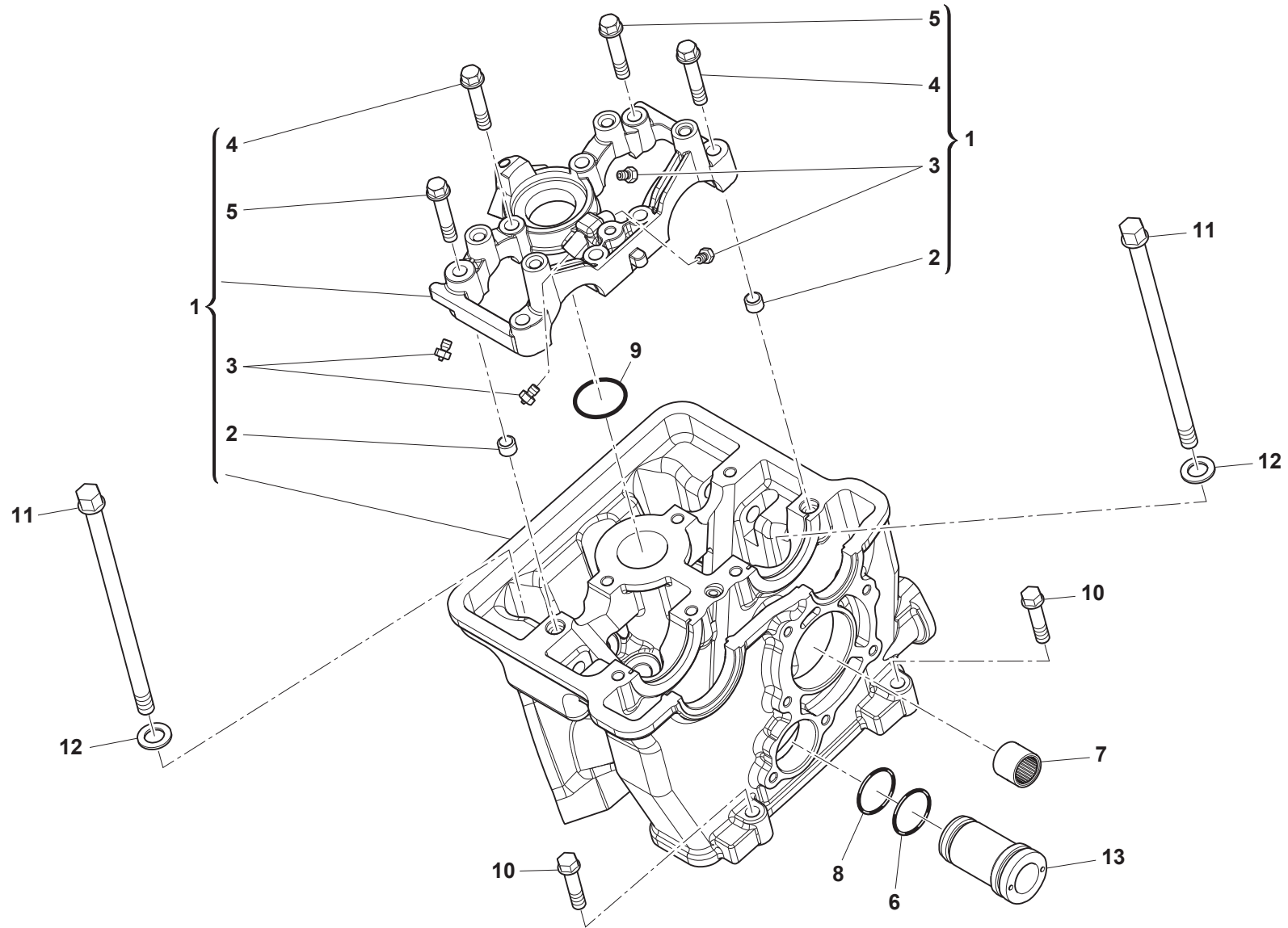

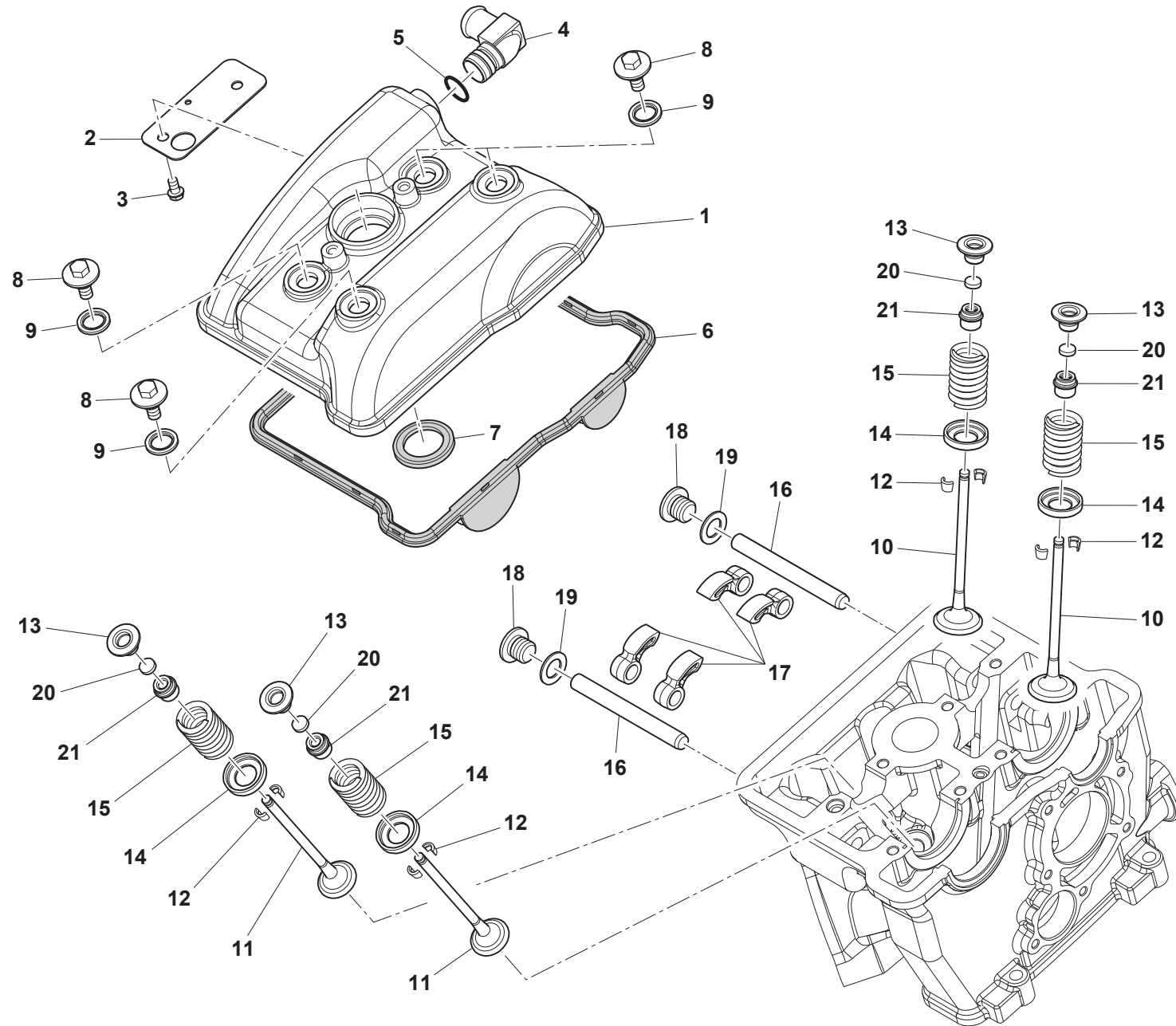

VEDI TAVOLA 3
SEE DRAWING 3
VOIR TABLE 3
SEHEN BILD 3
VER TABLA 3



Note Notes Marke Notas	Pos. No. Index Pos.	N. Cod. Code No. Nr. Code Code Nr N. Cod.	Q.tà Q.ty Q.te M.ge C.ad	DENOMINAZIONE	NAME	DESIGNATION	BESHREIBUNG	DENOMINACION
	1	22150325	1	COPERCHIO TESTA	HEAD COVER	COUVERCLE CULASSE	ZYLINDERKOPFDECKEL	TAPA CULATA
	2	73131648	1	PIASTRA BLOW BY	BLOW-BY PLATE	PLAQUE BLOW-BY	BLOW-BY PLATTE	PLACA BLOW-BY
	3	72012186	2	VITE TE M5x10	SCREW TE M5x10	VIS TE M5x10	SCHRAUBE TE M5x10	TORNILLO TC M6x12
	4	8000A7039	1	RACCORDO SFIATO	BREATHER PIPE FITTING	RACCORD RENIFLARD	ENTLÜFTUNGSANSCHLUSS	RACOR RESPIRADERO
	5	72150213	1	ANELLO OR	O-RING	JOINT TORIQUE	O-RING	JUNTA TORICA
	6	72150230	1	GUARNIZIONE COPERCHIO TESTA	HEAD COVER GASKET	JOINT COUVERCLE CULASSE	DICHTUNG ZYLINDERKOPFDECKEL	JUNTA TAPA CULATA
	7	72150233	1	GOMMINO	RUBBER RING	JOINT EN CAOUTCHOUC	GUMMSCHEIBE	GOMA
	8	72012182	4	VITE	BOLT	VIS	SCHRAUBE	TORNILLO
	9	73012547	4	RONDELLA GM2000	GM2000 WASHER	RONDELLE GM2000	UNTERLEGSSCHEIBE GM2000	ARANDELA
	10	22020098	2	VALVOLA DI ASPIRAZIONE	INTAKE VALVE	SOUPAPE D'ADMISSION	EINLASSVENTIL	VÁLVULA DE ADMISIÓN
	11	22020099	2	VALVOLA DI SCARICO	EXHAUST VALVE	SOUPAPE D'ÉCHAPPEMENT	AUSLASSVENTIL	VÁLVULA DE ESCAPE
	12	22040010	8	SEMICONO	COLLET	DEMI-CONE	KEGELHÄLFTE	SEMICONO
	13	22030022	4	SCODELLINO	RETAINER	RONDELLE A RESSORT	FEDERTELLER	ASIENTO
	14	22030023	4	PIATTELLO	PLATE	PLATEAU	FEDERTELLER	PLATO
	15	72120165	4	MOLLA PER VALVOLA	VALVE SPRING	RESSORT POUR SOUPAPE	FEDER FÜR VENTIL	MUELLE PARA VALVULA
	16	22070033	2	PERNO	PIN	AXE	BOLZEN	EJE
	17	22050045	4	BILANCIERE	ROCKER ARM	CULBUTEUR	UMLENK-HEBEL	BALANCÍN
	18	72012177	2	TAPPO	PLUG	BOUCHON	STOPFEN	TAPON
	19	72040667	2	ROSETTA	WASHER	RONDELLE	UNTERLEGSSCHEIBE	ARANDELA
	20	22020100	4	PASTIGLIA VALVOLA 1,2 mm - 2,4 mm	1,2 mm - 2,4 mm PAD, VALVE ADJUSTING	PASTILLE REGLAGE CULBETEUR 1,2 mm - 2,4 mm	VENTILKAEPPCHEN 1,2 mm - 2,4 mm	REGISTRO BALANCIN 1,2 mm - 2,4 mm
	21	72110237	4	TENUTA VALVOLE	VALVE SEALING	D'ETANCHEITE SOUPAPES	VENTILDICHTUNGS	ESTANQUEIDAD VALVULAS Ø5

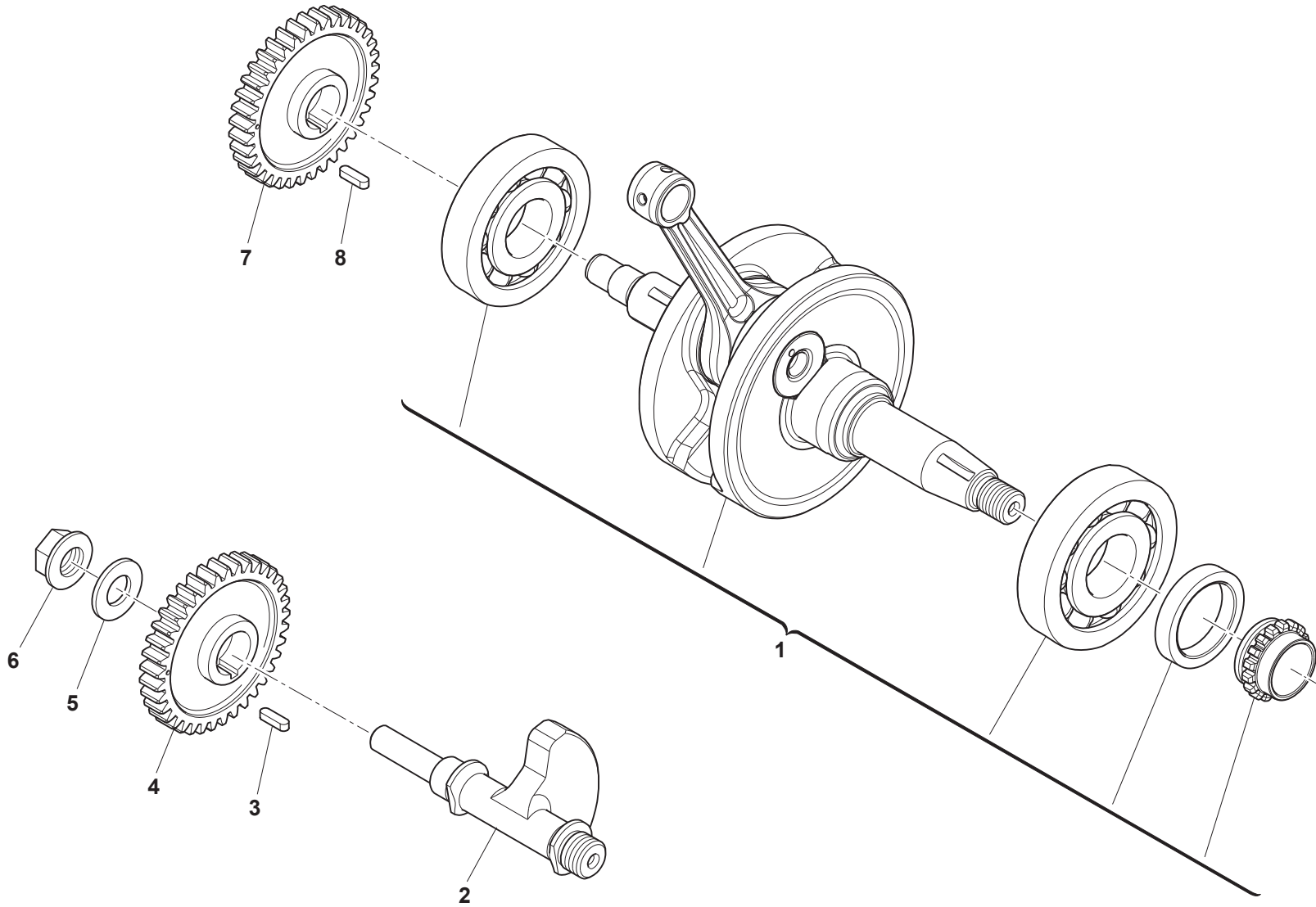



Note Notes Notes Marke Notas	Pos. No. N. Index Pos.	N. Cod. Code No. Nr. Code Code Nr N. Cod.	Q.tà Q.ty Q.te M.ge C.ad	DENOMINAZIONE	NAME	DESIGNATION	BESHREIBUNG	DENOMINACION
	1	21010216	1	ALBERO MOTORE COMPLETO	COMPLETE CRANKSHAFT	VILEBREQUIN COMPLET	KURBELWELLE KOMPLETT	CIGÜEÑAL COMPLETO
	2	21090022	1	CONTRALBERO	COUNTERSHAFT	ARBRE DE RENVOI	VORGELEGEWELLE	CONTRAEJE
	3	21210011	1	LINGUETTA 5x5x12	5x5x12 TAB	LANGUETTE 5x5x12	FEDERKEIL 5x5x12	LENGÜETA 5x5x12
	4	24020094	1	INGRANAGGIO	GEAR	PIGNON	ZAHNRAD	ENGRANAJE
	5	72040670	1	ROSETTA	WASHER	RONDELLE	UNTERLEGSCHIEBE	ARANDELA
	6	72020545	1	DADO M10x1	M10x1 NUT	ECROU M10x1	MUTTER M10x1	TUERCA M10x1
	7	24020093	1	INGRANAGGIO	GEAR	PIGNON	ZAHNRAD	ENGRANAJE
	8	21210014	1	LINGUETTA	TAB	LANGUETTE	FEDERKEIL	LENGÜETA

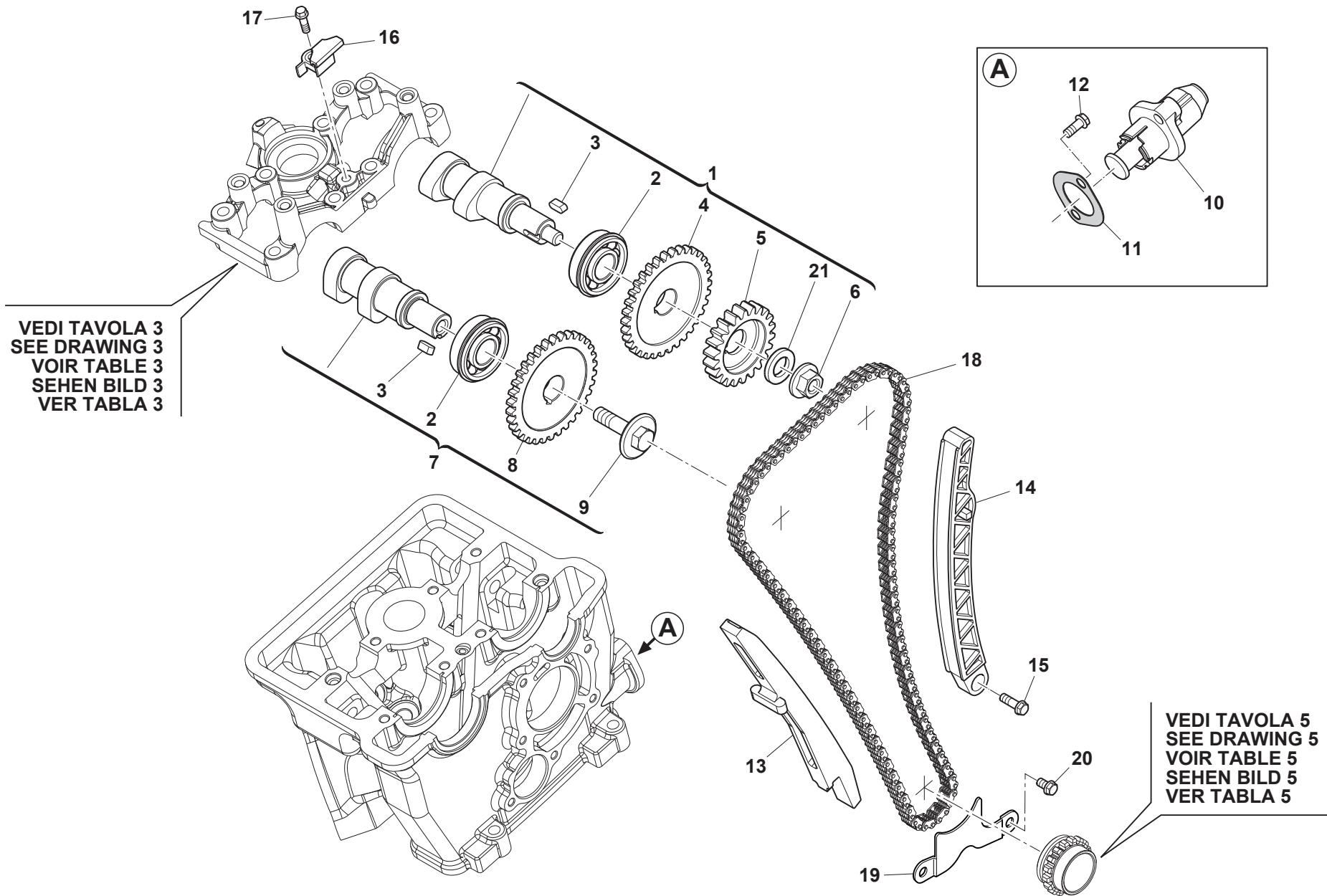



ACE OF SPADES 125 OUTLAW 125

DISTRIBUZIONE - VALVE TIMING DISTRIBUTION - VENTILSTEUERUNG DISTRIBUCION

TAVOLA
DRAWING
TABLE
BILD
TABLA

6

Note Notes Notes Marke Notas	Pos. No. Index Pos.	N. Cod. Code No. Nr. Code Code Nr N. Cod.	Q.tà Q.ty Q.te M.ge C.ad	DENOMINAZIONE	NAME	DESIGNATION	BESHREIBUNG	DENOMINACION
	1	76220003	1	ALBERO A CAMME ASPIRAZIONE	INTAKE CAMSHAFT	ARBRE A CAMES ADMISSION	NOCKENWELLE EINLASS	ARBOL DE LEVAS ADMISIÓN
	2	22190019	2	CUSCINETTO RADIALE 6202NR	RADIAL BEARING 6202NR	ROULEMENT RADIAL 6202NR	RADIALLAGER 6202NR	COJINETE RADIAL 6202NR
	3	21210012	2	LINGUETTA	TAB	LANGUETTE	FEDERKEIL	LENGÜETA
	4	15170125	1	INGRANAGGIO CONDOTTO	DRIVEN GEAR	ENGRENAGE CONDUIT	ANGETRIEBENES ZAHNRAD	ENGRANAJE CONDUCIDO
	5	17010012	1	INGRANAGGIO POMPA	PUMP GEAR	ENGRENAGE POMPE	PUMPENZAHNRAD	ENGRANAJE BOMBA
	6	72020544	1	DADO FLANGIATO M8	FLANGED NUT M8	ECROU BRIDE M8	FLANSCHMUTTER M8	TUERCA CON BRIDA M8
	7	76220004	1	ALBERO A CAMME SCARICO	EXHAUST CAMSHAFT	ARBRE A CAMES ECHAPPEMENT	NOCKENWELLE AUSLASS	ARBOL DE LEVAS ESCAPE
	8	15170126	1	INGRANAGGIO CONDOTTO	DRIVEN GEAR	ENGRENAGE CONDUIT	ANGETRIEBENES ZAHNRAD	ENGRANAJE CONDUCIDO
	9	72012176	1	VITE SPECIALE M8x30	M8x30 SPECIAL BOLT	VIS SPÉCIAUX M8x30	SPEZIALSCHRAUBE M8x30	TORNILLO ESPECIAL M8x30
	10	8000A6950	1	TENDICATENA COMPLETO	COMPLETE CHAIN TENSIONER	TENDEUR DE CHAÎNE COMPLET	KETTENSANNER KOMPLETT	ENSOR DE CADENA COMPLETO
	11	8000A6954	1	GUARNIZIONE	GASKET	JOINT	DICHTUNG	JUNTA
	12	72010163	2	VITE TEF M6x25	FLANGED EXAGON HEAD SCREW M6x25	BOULON DE BRIDE M6x25	FLANSCHENSCHRAUBE M6x25	TORNILLO DE REBORDE M6x25
	13	73012518	1	PATTINO FISSO	FIXED SLIDER	PATIN FIXE	FESTE KETTENSANNERAUFLAGE	PATÍN FIJO
	14	73012517	1	PATTINO MOBILE	MOVING SLIDER	PATIN MOBILE	BEWEGLICHE KETTENSANNERAUFLAGE	PATÍN MÓVIL
	15	72012183	1	VITE	BOLT	VIS	SCHRAUBE	TORNILLO
	16	73012519	1	PATTINO	SLIDER	PATIN	SPANNERAUFLAGE	PATÍN
	17	72010157	1	VITE TEF M6x16	FLANGED EXAGON HEAD SCREW M6x16	BOULON DE BRIDE M6x16	FLANSCHENSCHRAUBE M6x16	TORNILLO DE REBORDE M6x16
	18	15160047	1	CATENA DISTRIBUZIONE (122 MAGLIE)	TIMING CHAIN (122 LINKS)	CHAÎNE DE DISTRIBUTION (122 MAILLONS)	VENTILSTEUERKETTE (122 GLIEDER)	CADENA DISTRIBUCION (122 ESLABONES)
	19	73131547	1	PIASTRA GUIDACATENA DISTRIBUZIONE	TIMING CHAIN GUIDE PLATE	PLAQUE GUIDE DE CHAÎNE DISTRIBUTION	PLATTE KETTENFÜHRUNG VENTILSTEUER	PLACA GUÍA CADENA DISTRIBUCION
	20	72010157	1	VITE TEF M6x16	FLANGED EXAGON HEAD SCREW M6x16	BOULON DE BRIDE M6x16	FLANSCHENSCHRAUBE M6x16	TORNILLO DE REBORDE M6x16
	21	72040431	1	ROSETTA PIANA IN ACCIAIO 8x20x2	IRON FLAT WASHER 8x20x2	RONDELLE PLATE 8x20x2	FLACHE UNTERLEGSCHIEBE 8x20x2	ARANDELA PLANA 8x20x2

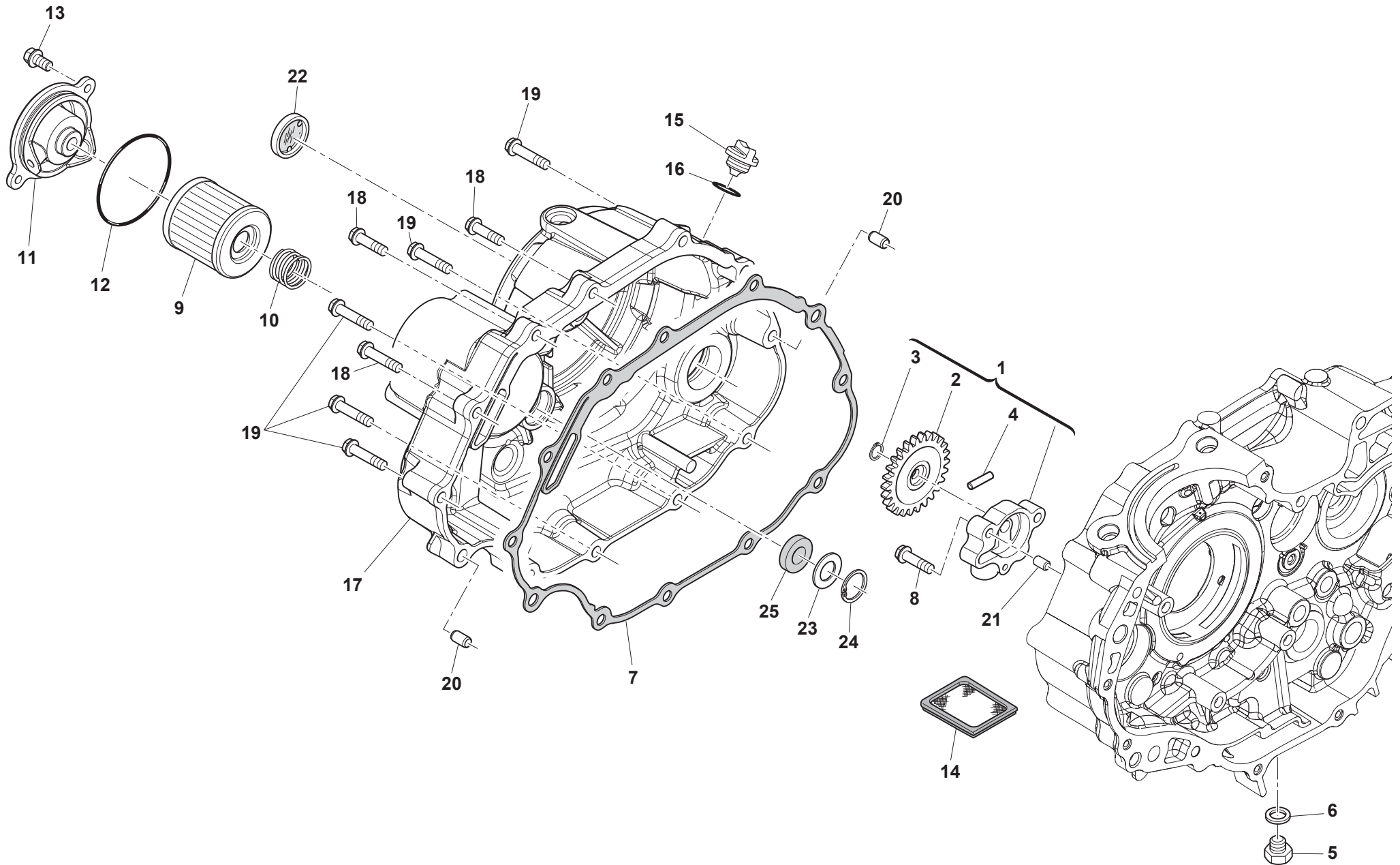



ACE OF SPADES 125 OUTLAW 125

LUBRIFICAZIONE - LUBRIFICATION GRAISSAGE - SCHMIERUNG LUBRICACION

TAVOLA
DRAWING
TABLE
BILD
TABLA

7

Note Notes Notes Marke Notas	Pos. No. N. Index Pos.	N. Cod. Code No. Nr. Code Code Nr N. Cod.	Q.tà Q.ty Q.te M.ge C.ad	DENOMINAZIONE	NAME	DESIGNATION	BESHREIBUNG	DENOMINACION
	1	20010078	1	POMPA OLIO COMPLETA	COMPLETE OIL PUMP	POMPE A HUILE COMPLETE	ÖLPUMPE KOMPLETT	BOMBA ACEITE COMPLETA
	2	20080022	1	INGRANAGGIO POMPA OLIO	OIL PUMP GEAR	ENGRENAGE POMPE	PUMPENZAHNRAD	ENGRANAJE BOMBA
	3	20080024	1	ANELLO DI FERMO	RETAINING RING	BAGUE D'ARRET	SICHERUNGSRING	ANILLO DE RETENCION
	4	20080023	1	RULLINO Ø3x16	RØ3x16 OLLER	AIGUILLE Ø3x16	ROLLE Ø3x16	RODILLO Ø3x16
	5	72012089	1	TAPPO SCARICO OLIO	OIL DRAIN PLUG	BOUCHON VIDANGE D'HUILE	OLABLASSSCHRAUBE	TAPON VACIADO ACEITE
	6	72040159	1	ROSETTA	WASHER	RONDELLE	UNTERLEGSSCHEIBE	ARANDELA
	7	72130623	1	GUARNIZIONE COPERCHIO FRIZIONE	GASKET	JOINT	DICHTUNG	JUNTA
	8	72010168	2	VITE TEF M6x30	FLANGED EXAGON HEAD SCREW M6x30	BOULON DE BRIDE M6x30	SCHRAUBE M6x30	TORNILLO M6x30
	9	8000B0593	1	FILTRO OLIO A CARTUCCIA	OIL CARTRIDGE FILTER	FILTRE À HUILE À CARTOUCHE	PATRONEN-ÖLFILTER	FILTRO ACEITE DE CARTUCHO
	10	72120166	1	MOLLA PREMI FILTRO-CARTUCCIA	FILTER/CARTRIDGE PRESSING SPRING	RESSORT PRESSE FILTRE-CARTOUCHE	DRUCKFEDER FILTER-PATRONE	MUELLE PRENSA FILTRO-CARTUCHO
	11	14090088	1	COPERCHIO FILTRO OLIO	OIL FILTER COVER	COUVERCLE	DECKEL	TAPA
	12	72150237	1	ANELLO OR	O-RING	JOINT TORIQUE	O-RING	JUNTA TORICA
	13	72010157	2	VITE M6x16	SCREW M6x16	VIS M6x16	SCHRAUBE M6x16	TORNILLO M6x16
	14	11060002	1	FILTRO A RETE	MESH FILTER	FILTRE À GRILLE	NETZFILTER	FILTRO DE RED
	15	14060064	1	TAPPO CARICO OLIO	OIL FILLER PLUG	BOUCHON DE REMPLISSAGE HUILE	ÖLEINFÜLLSCHRAUBE	TAPON LLENADO ACEITE
	16	72150018	1	ANELLO OR	O-RING	JOINT TORIQUE	O-RING	JUNTA TORICA
	17	13012114	1	COPERCHIO FRIZIONE	CLUTCH COVER	COUVERCLE D'EMBRAYAGE	KUPPLUNGSDECKEL	TAPA EMBRAGUE
	18	72010387	3	VITE TEF M6x28	FLANGED EXAGON HEAD SCREW M6x28	BOULON DE BRIDE M6x28	FLANSCHENSCHRAUBE M6x28	TORNILLO DE REBORDE M6x28
	19	72010389	9	VITE TEF M6x40	FLANGED EXAGON HEAD SCREW M6x40	BOULON DE BRIDE M6x40	SCHRAUBE M6x40	TORNILLO M6x40
	20	72060012	2	BUSSOLA	BUSHING	DOUILLE	BUCHSE	CASQUILLO
	21	72060013	2	BUSSOLA	BUSHING	DOUILLE	BUCHSE	CASQUILLO
	22	800073529	1	OBLÒ PER LIVELLO OLIO	OIL LEVEL INSPECTION SIGHT GLASS	HUBLOT DE CONTRÔLE NIVEAU D'HUILE	SCHAUGLAS FÜR ÖLSTAND	MIRILLA PARA NIVEL ACEITE
	23	72040677	1	ROSETTA	WASHER	RONDELLE	UNTERLEGSSCHEIBE	ARANDELA
	24	72080073	1	ANELLO ELASTICO	CIRCLIP	CIRCLIP	SPRENGRING	ANILLO ELASTICO
	25	8A0028855	1	ANELLO DI TENUTA Ø12xØ18x5	Ø12xØ18x5 SEALING RING	BAGUE D'ETANCHEITE Ø12xØ18x5	DICHTUNGSRING Ø12xØ18x5	ANILLO DE ESTANQUEIDAD Ø12xØ18x5

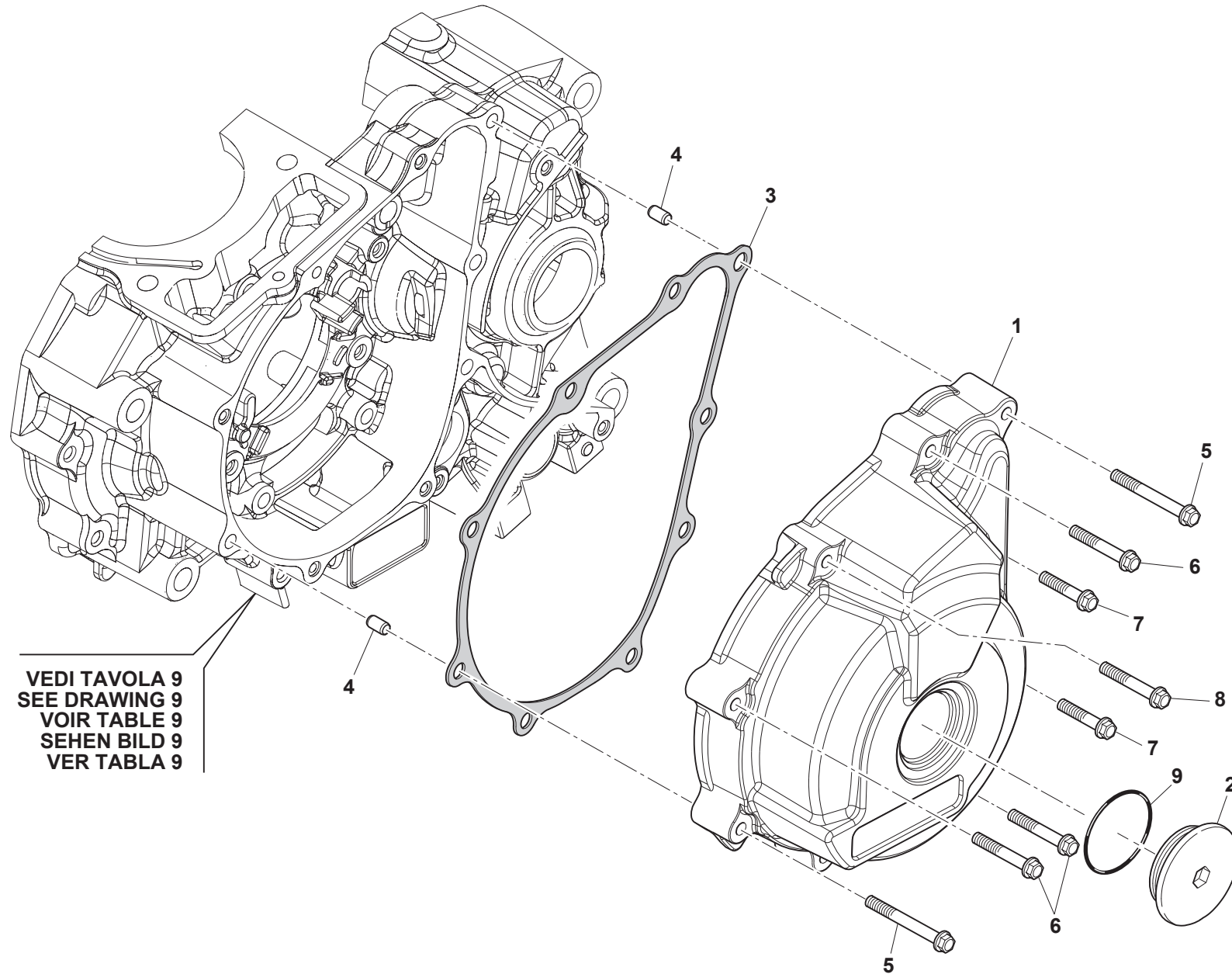

VEDI TAVOLA 9
SEE DRAWING 9
VOIR TABLE 9
SEHEN BILD 9
VER TABLA 9

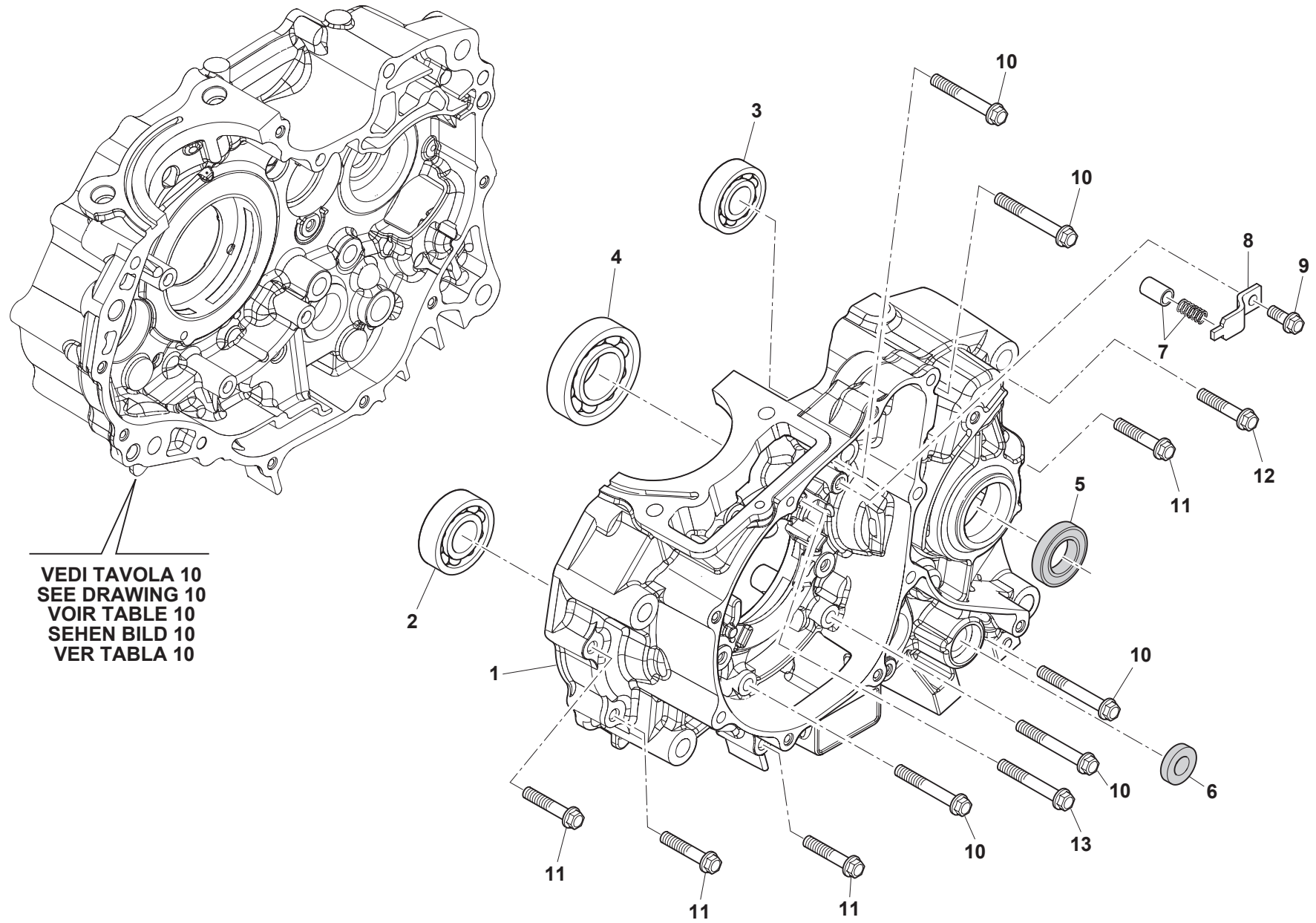

VEDI TAVOLA 10
SEE DRAWING 10
VOIR TABLE 10
SEHEN BILD 10
VER TABLA 10



Note Notes Notes Marke Notas	Pos. No. N. Index Pos.	N. Cod. Code No. Nr. Code Code Nr N. Cod.	Q.tà Q.ty Q.te M.ge C.ad	DENOMINAZIONE	NAME	DESIGNATION	BESHREIBUNG	DENOMINACION
	1	11010698	1	CARTER SINISTRO	LEFT CRANKCASE	CARTER G.	DECKEL R.	CÁRTER DER.
	2	70090143	1	CUSCINETTO CONTRALBERO Ø15xØ35x11	Ø15xØ35x11 BEARING COUNTERSHAFT	RADIAL ARBRE DE RENVOI Ø15xØ35x11	LAGER VORGELEGEWELLE Ø15xØ35x11	COJINETE CONTRAEJE Ø15xØ35x11
	3	70090137	1	CUSCINETTO ALBERO SECONDARIO Ø20Ø47x14	Ø20Ø47x14 OUTPUT SHAFT BEARING	ROULEMENT ARBRE SECONDAIRE Ø20Ø47x14	VORGELEGEWELLE AGER Ø20Ø47x14	COJINETE ARBOL SECONDARIO Ø20Ø47x14
	4	70090005	1	CUSCINETTO ALBERO PRIMARIO Ø12xØ32x10	Ø12xØ32x10 INPUT SHAFT BEARING	ROULEMENT ARBRE PRIMAIRE Ø12xØ32x10	HAUPTANTRIEBSWELLE LAGER Ø12xØ32x10	COJINETE ARBOL PRIMARIO Ø12xØ32x10
	5	72110011	1	ANELLO DI TENUTA Ø20xØ34x7	Ø20xØ34x7 SEALING RING	BAGUE D'ETANCHEITE Ø20xØ34x7	DICHTUNGSRING Ø20xØ34x7	ANILLO DE ESTANQUEIDAD Ø20xØ34x7
	6	72110012	1	ANELLO DI TENUTA Ø14x22x5	SEALING RING Ø14x22x5	BAGUE D'ETANCHEITE Ø14x22x5	DICHTUNGSRING Ø14x22x5	ANILLO DE ESTANQUEIDAD Ø14x22x5
	7	11080005	1	PUNTALE + MOLLA	PUSH ROD + SPRING	EMBOUT + RESSORT	STIFT + FEDER	PUNTA + MUELLE
	8	73131647	1	PIASTRA PUNTALE	PUSH ROD PLATE	PLAQUE EMBOUT	PLATTE STIFT	PLACA PUNTA
	9	72010157	1	VITE M6x16	SCREW M6x16	VIS M6x16	SCHRAUBE M6x16	TORNILLO M6x16
	10	72010393	5	VITE TEF M6x70	FLANGED EXAGON HEAD SCREW M6x70	BOULON DE BRIDE M6x70	SCHRAUBE M6x70	TORNILLO M6x70
	11	72010389	6	VITE TEF M6x40	FLANGED EXAGON HEAD SCREW M6x40	BOULON DE BRIDE M6x40	SCHRAUBE M6x40	TORNILLO M6x40
	12	72010169	1	VITE TEF M6x35	FLANGED EXAGON HEAD SCREW M6x35	BOULON DE BRIDE M6x35	FLANSCHENSCHRAUBE M6x35	TORNILLO DE REBORDE M6x35
	13	72010392	1	VITE TEF M6x65	FLANGED EXAGON HEAD SCREW M6x65	BOULON DE BRIDE M6x65	SCHRAUBE M6x65	TORNILLO M6x65

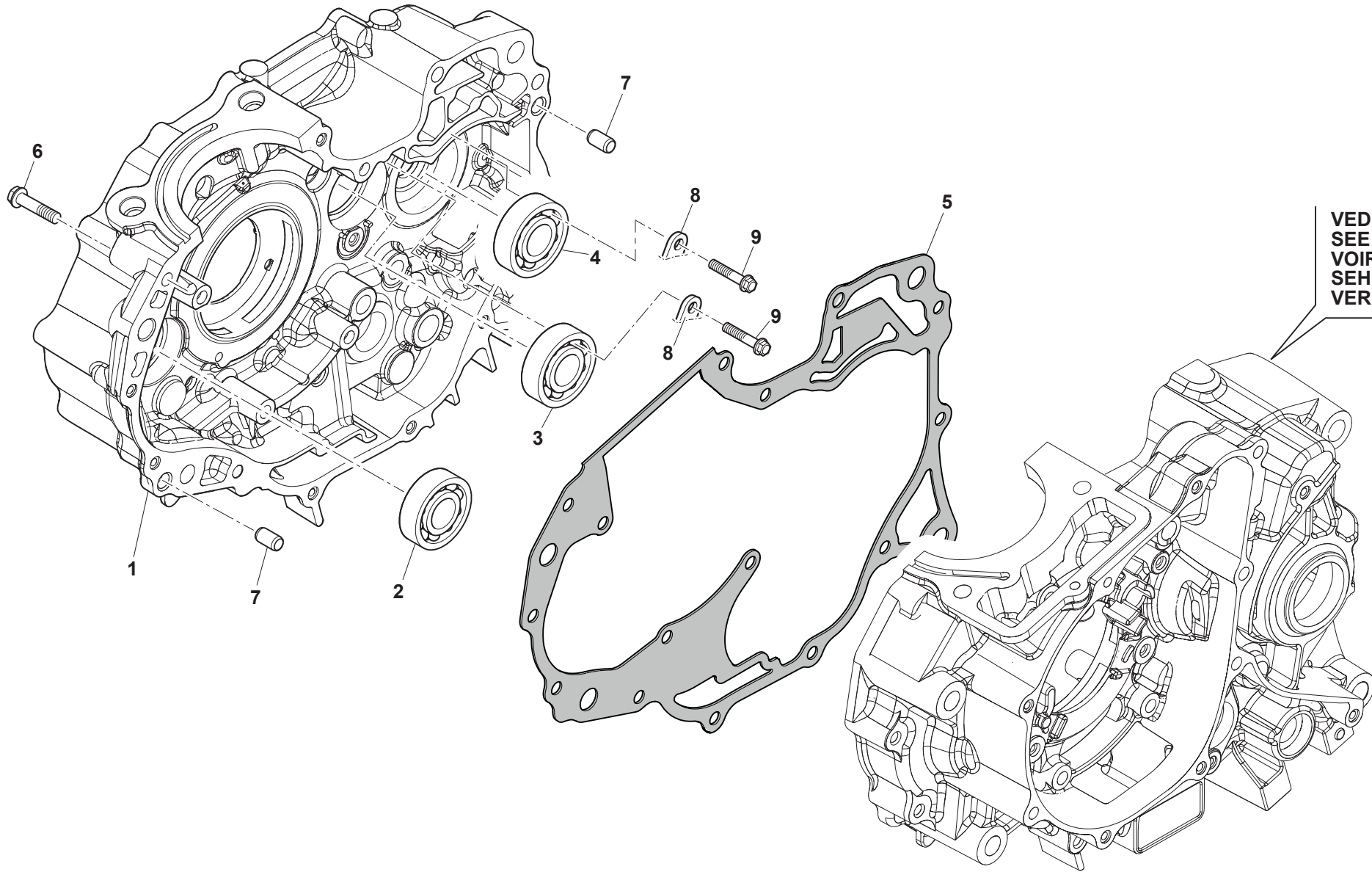

VEDI TAVOLA 9
SEE DRAWING 9
VOIR TABLE 9
SEHEN BILD 9
VER TABLA 9



Note Notes Notes Marke Notas	Pos. No. Index Pos.	N. Cod. Code No. Nr. Code Code Nr N. Cod.	Q.tà Q.ty Q.te M.ge C.ad	DENOMINAZIONE	NAME	DESIGNATION	BESHREIBUNG	DENOMINACION
	1	12010652	1	CARTER DESTRO	RIGHT CRANKCASE	CARTER D.	GEHAUSE R.	CARTER DER.
	2	70090143	1	CUSCINETTO CONTRALBERO Ø15xØ35x11	Ø15xØ35x11 BEARING COUNTERSHAFT	RADIAL ARBRE DE RENVOI Ø15xØ35x11	LAGER VORGELEGEWELLE Ø15xØ35x11	COJINETE CONTRAEJE Ø15xØ35x11
	3	70090011	1	CUSCINETTO ALBERO PRIMARIO Ø17xØ40x12	Ø17xØ40x12 INPUT SHAFT BEARING	ROULEMENT ARBRE PRIMAIRE Ø17xØ40x12	HAUPTANTRIEBSWELLE LAGER Ø17xØ40x12	COJINETE ARBOL PRIMARIO Ø17xØ40x12
	4	70090138	1	CUSCINETTO ALBERO SECONDARIO Ø17Ø40x12	Ø17Ø40x12 OUTPUT SHAFT BEARING	ROULEMENT ARBRE SECONDAIRE Ø17Ø40x12	VORGELEGEWELLE AGER Ø17Ø40x12	COJINETE ARBOL SECONDARIO Ø17Ø40x12
	5	72130610	1	GUARNIZIONE CARTER	GASKET CRANKCASE	CARTER JOINT	GEHAUSE DICHTUNG	CARTER JUNTA
	6	72010390	1	VITE TEF M6x45	FLANGED EXAGON HEAD SCREW M6x45	BOULON DE BRIDE M6x45	SCHRAUBE M6x45	TORNILLO M6x45
	7	72060012	2	BUSSOLA DI CENTRAGGIO Ø8x14	BUSH Ø8x14	DOUILLE Ø8x14	BUCHSE Ø8x14	CASQUILLO Ø8x14
	8	73131276	2	PIASTRINA RITEGNO CUSCINETTO	BEARING PRESSURE PLATE	PLAQUE DE RETENUE ROULEMENT	RÜCKHALTEPLÄTTCHEN LAGER	PLACA RETENCIÓN COJINETE
	9	72010157	2	VITE TEF M6x16	FLANGED EXAGON HEAD SCREW M6x16	BOULON DE BRIDE M6x16	FLANSCHENSCHRAUBE M6x16	TORNILLO DE REBORDE M6x16

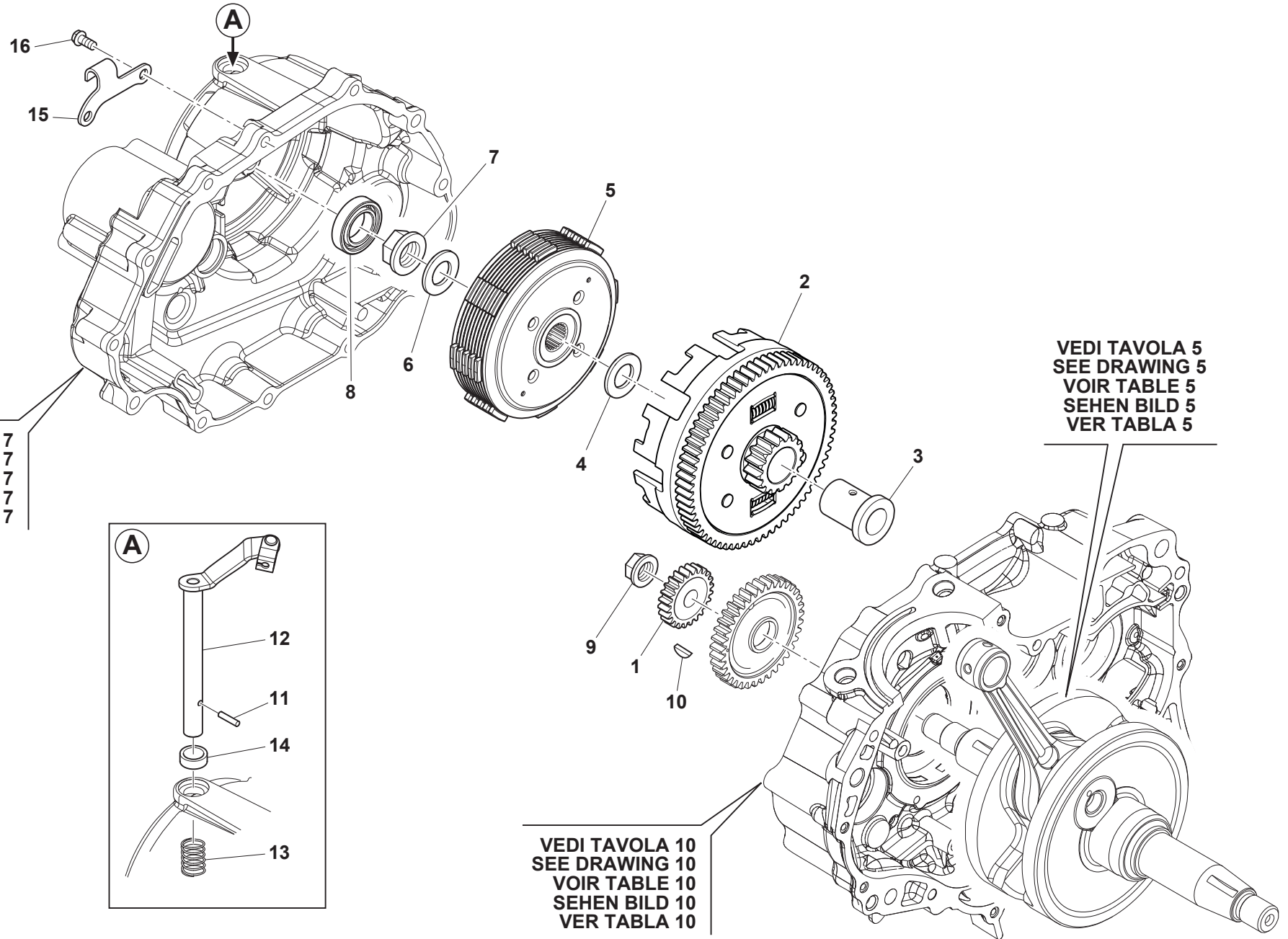

VEDI TAVOLA 7
SEE DRAWING 7
VOIR TABLE 7
SEHEN BILD 7
VER TABLA 7

VEDI TAVOLA 5
SEE DRAWING 5
VOIR TABLE 5
SEHEN BILD 5
VER TABLA 5

VEDI TAVOLA 10
SEE DRAWING 10
VOIR TABLE 10
SEHEN BILD 10
VER TABLA 10



Note Notes Notes Marke Notas	Pos. No. Index Pos.	N. Cod. Code No. Nr. Code Code Nr N. Cod.	Q.tà Q.ty Q.te M.ge C.ad	DENOMINAZIONE	NAME	DESIGNATION	BESHREIBUNG	DENOMINACION
	1	24020060	1	PIGNONE PRIMARIO	INPUT SPROCKET	PIGNON PRIMAIRE	RITZELWELLE	PINON PRIMARIO
	2	24070311	1	INGRANAGGIO CONDOTTO	DRIVEN GEAR	ENGRENAGE CONDUIT	ANGETRIEBENES ZAHNRAD	ENGRANAJE CONDUCTIDO
	3	24070155	1	BUSSOLA	BUSHING	DOUILLE	BUCHSE	CASQUILLO
	4	24070312	1	ROSETTA	WASHER	RONDELLE	UNTERLEGSCHEIBE	ARANDELA
	5	24070248	1	GRUPPO DISCHI FRIZIONE	CLUTCH PLATE ASSY	ENSEMBLE DISQUES EMBRAYAGE	KUPPLUNGSSCHEIBENGRUPPE	GRUPO DISCOS EMBRAGUE
	6	24070219	1	ROSETTA 14,2x29x2,8	WASHER 14,2x29x2,8	RONDELLE 14,2x29x2,8	UNTERLEGSCHEIBE 14,2x29x2,8	ARANDELA 14,2x29x2,8
	7	24070221	1	DADO FLANGIATO M14x1	FLANGED NUT M14x1	ECROU BRIDE M14x1	FLANSMUTTER M14x1	TUERCA CON BRIDA M14x1
	8	24070223	1	CUSCINETTO 6003	BEARING 6003	ROULEMENT 6003	LAGER 6003	COJINETE 6003
	9	72020546	1	DADO FLANGIATO M14x1 SINISTRO	LEFT FLANGED NUT M14x1	ECROU BRIDE M14x1 GAUCHE	FLANSMUTTER M14x1 LINKS	TUERCA CON BRIDA M14x1 IZQUIERDO
	10	21210014	1	CHIAVETTA 4x4	4x4 WOODRUFF KEY	CLÉ 4x4	FEDERKEIL 4x4	MEMORIA 4x4
	11	72060031	1	SPINA	DOWEL	GOUPILLE	STIFT	CLAVIJA
	12	24030070	1	LEVA COMANDO FRIZIONE	CLUTCH CONTROL LEVER	LEVIER DE COM. EMBRAYAGE	KUPPLUNGSHABEL	PALANCA MANDO EMBRAGUE
	13	72120103	1	MOLLA	SPRING	RESSORT	FEDER	MUELLE
	14	72110024	1	ANELLO DI TENUTA Ø12xØ18x5	Ø12xØ18x5 SEALING RING	BAGUE D'ETANCHEITE Ø12xØ18x5	DICHTUNGSRING Ø12xØ18x5	ANILLO DE ESTANQUEIDAD Ø12xØ18x5
	15	73131855	1	PIASTRINA	PLATE	PLAQUETTE	PLÄTTCHEN	PLACA
	16	72010387	2	VITE TEF M6x28	FLANGED EXAGON HEAD SCREW M6x28	BOULON DE BRIDE M6x28	FLANSCHENSCHRAUBE M6x28	TORNILLO DE REBORDE M6x28

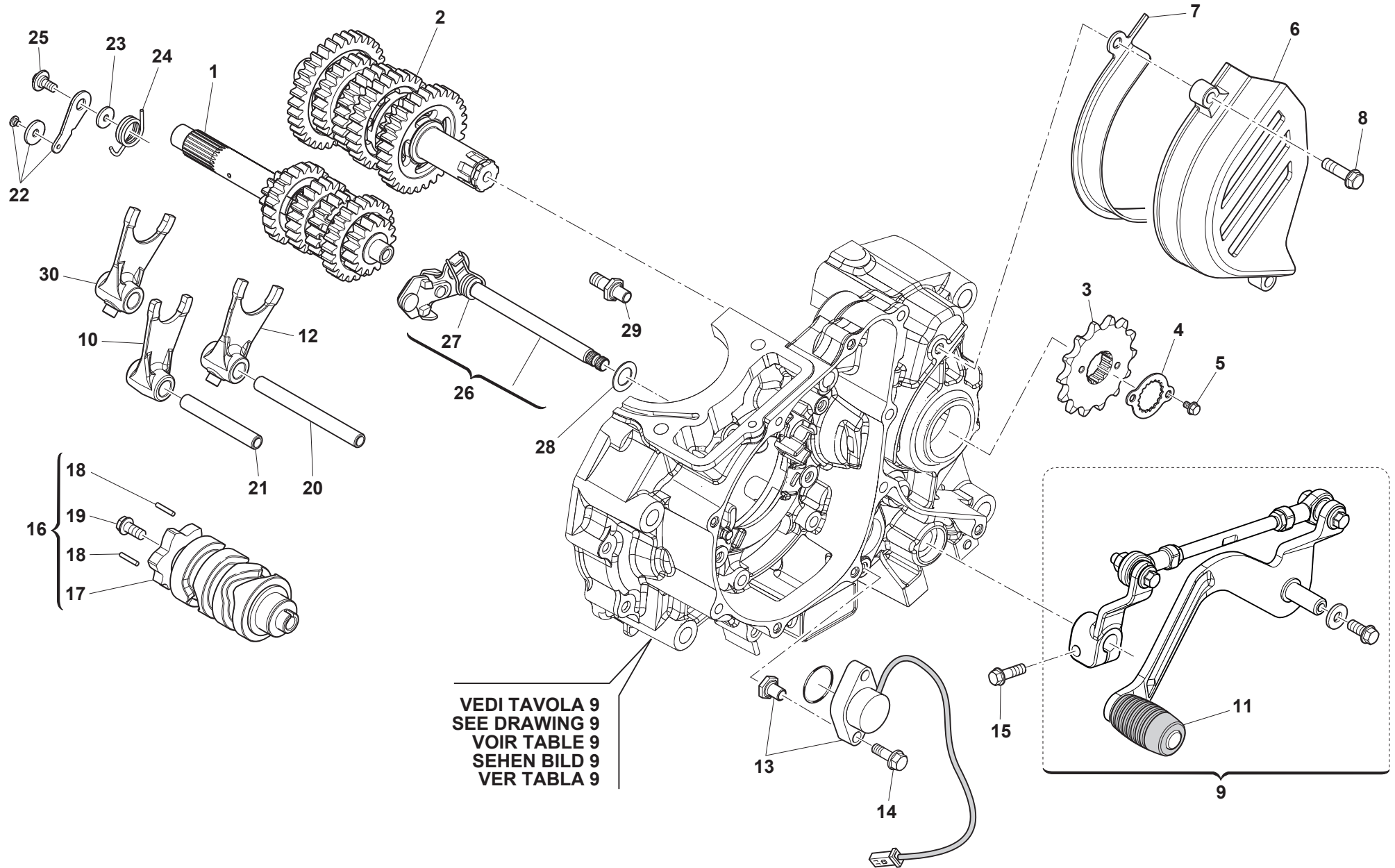



Note Notes Marke Notas	Pos. No. N. Index Pos.	N. Cod. Code No. Nr. Code Code Nr N. Cod.	Q.tà Q.ty Q.te M.ge C.ad	DENOMINAZIONE	NAME	DESIGNATION	BESHREIBUNG	DENOMINACION
	1	15020130	1	ASSIEME ALBERO PRIMARIO	INPUT SHAFT ASSY	ARBRE PRIMAIRE COMPL.	ZUSAMMENBAU HAUPTANTRIEBSWELLE	CONJUNTO ARBOL PRIMARIO
	2	15030170	1	ASSIEME ALBERO SECONDARIO	OUTPUT SHAFT ASSY	ARBRE SECONDAIRE COMPL.	ZUSAMMENBAU VORGELEGEWELLE	CONJUNTO ARBOL SECONDARIO
	3	15170128	1	PIGNONE USCITA CAMBIO Z=14	TRANSMISSION SPROCKET T=14	PIGNON SORTIE BOÎTE DE VITESSES Z=14	GETRIEBE-AUSGANGSRITZEL Z=14	PINON SALIDA CAMBIO Z=14
	4	73130522	1	PIASTRA FISSAGGIO PIGNONE	PINION FIXING BRACKET	PLAQUE PIGNON	RITZELPLATTE	PLACA PINON
	5	72010089	2	VITE M6x10	M6x10 BOLT	VIS M6x10	SCHRAUBE M6x10	TORNILLO M6x10
	6	M000P00335	1	COPERCHIO PIGNONE CATENA	CHAIN SPROCKET COVER	COUVERCLE PIGNON CHAÎNE	DECKEL KETTENRITZEL	TAPA PINON CADENA
	7	M000P00336	1	PIASTRINA	PLATE	PLAQUETTE	PLÄTTCHEN	PLACA
	8	Z00062728	2	VITE TEF M6x20	FLANGED EXAGON HEAD SCREW M6x20	BOULON DE BRIDE M6x20	SCHRAUBE M6x20	TORNILLO M6x20
	9	F000A03411	1	ASS. LEVA COMANDO CAMBIO	GEAR CONTROL LEVER ASSY	LEVIER DE COM. BOÎTE DE VITESSES COMPL.	ZSB. SCHALTHEBEL	CONJ. PALANCA MANDO CAMBIO
	10	15140055	1	FORCELLA INGRANAGGIO 5ª E 6ª VELOCITÀ	5TH AND 6TH GEAR FORK	FOURCHE PIGNON 5ÈME ET 6ÈME	GABEL ZAHNRAD 5. UND 6. GANG	HORQUILLA ENGRANAJE 5ª Y 6ª VEL.
	11	-	1	GOMMINO	RUBBER RING	JOINT EN CAOUTCHOUC	GUMMISCHEIBE	GOMA
	12	15140053	1	FORCELLA INGRANAGGIO 2ª E 3ª VELOCITÀ	2ND AND 3RD GEAR FORK	FOURCHE PIGNON 2ÈME ET 3ÈME	GABEL ZAHNRAD 2. UND 3. GANG	HORQUILLA ENGRANAJE 2ª Y 3ª VEL.
	13	11040208	1	SENSORE FOLLE	NEUTRAL POSITION SWITCH	CAPTEUR POINT MORT	LEERLAUFSSENSOR	SENSOR PUNTO MUERTO
	14	72010163	2	VITE M6x25	BOLT M6x25	VIS M6x25	SCHRAUBE M6x25	TORNILLO M6x25
	15	Z00062728	1	VITE TEF M6x20	FLANGED EXAGON HEAD SCREW M6x20	BOULON DE BRIDE M6x20	SCHRAUBE M6x20	TORNILLO M6x20
	16	76220006	1	ALBERO COMANDO FORCELLE	SELECTOR SHAFT	ARBRE DE COMMANDE FOURCHES	SCHALTGABELWELLE	EJE MANDO HORQUILLAS
	17	15090014	1	TAMBURO SELETTORE MARCE	GEAR SELECTOR DRUM	TAMBOUR SELECTEUR DE VITESSES	SCHALTWALZE	TAMBOR SELECTOR MARCHAS
	18	15180039	2	PERNO	PIN	AXE	BOLZEN	EJE
	19	72010095	1	VITE M6x20	M6x20 BOLT	VIS M6x20	SCHRAUBE M6x20	TORNILLO M6x20
	20	15140041	1	PERNO FORCELLA	FORK PIN	AXE FOURCHE	BOLZEN GABEL	EJE HORQUILLA
	21	15140042	1	PERNO FORCELLA	FORK PIN	AXE FOURCHE	BOLZEN GABEL	EJE HORQUILLA
	22	15080023	1	PIASTRINA DI FERMO SELETTORE	SELECTOR LOCK PLATE	PLAQUETTE D'ARRET SELECTEUR	HALTEPLÄTTCHEN SCHALTWALZE	PLACA DE FIJACION SELECTOR
	23	72040676	1	ROSETTA	WASHER	RONDELLE	UNTERLEGSSCHEIBE	ARANDELA
	24	72120121	1	MOLLA	SPRING	RESSORT	FEDER	MUELLE
	25	72011366	1	VITE	BOLT	VIS	SCHRAUBE	TORNILLO
	26	15070072	1	ASSIEME ALBERO SELETTORE	SELECTOR SHAFT ASSY	ARBRE SELECTEUR COMPL.	ZUSAMMENBAU SCHALTWALZENWELLE	CONJUNTO ARBOL SELECTOR
	27	15130036	1	MOLLA	SPRING	RESSORT	FEDER	MUELLE
	28	15130037	1	ROSETTA	WASHER	RONDELLE	UNTERLEGSSCHEIBE	ARANDELA
	29	72011772	1	PERNO DI FERMO SELETTORE	SELECTOR LOCK PIN	AXE D'ARRET SELECTEUR	BLOCKIERVORRICHTUNG SCHALTWALZE	EJE DE RETENCION SELECTOR
	30	15140054	1	FORCELLA INGRANAGGIO 1ª E 4ª VELOCITÀ	1ST, 4TH GEAR FORK	FOURCHE PIGNON 1ÈRE, 4ÈME	GABEL ZAHNRAD 1. UND 4. GANG	HORQUILLA ENGRANAJE 1ª Y 4ª VEL.
	31	M000P02527	1	ANELLO OR	O-RING	JOINT TORIQUE	O-RING	JUNTA TORICA

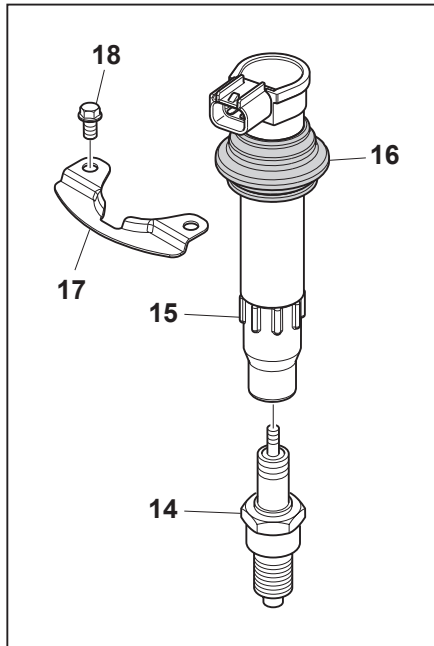
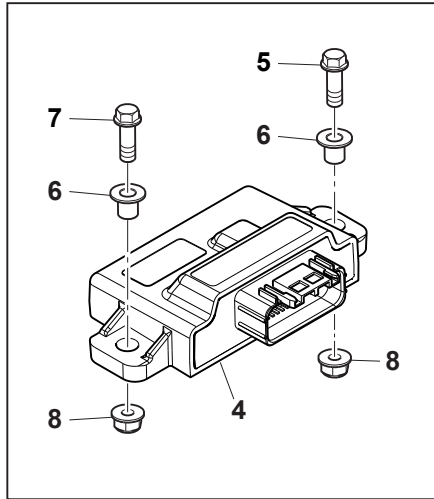

VEDI TAVOLA 14
SEE DRAWING 14
VOIR TABLE 14
SEHEN BILD 14
VER TABLA 14

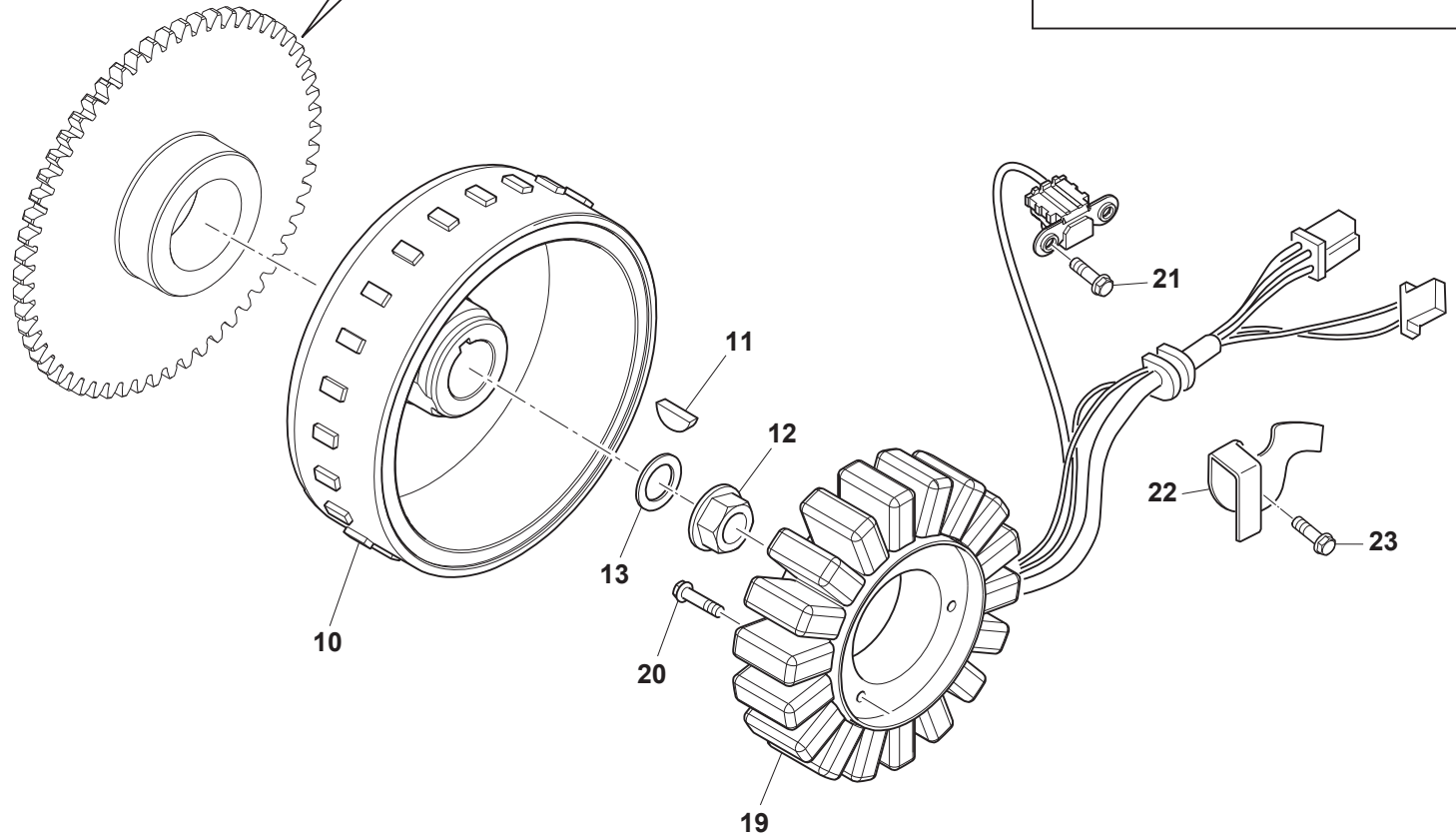
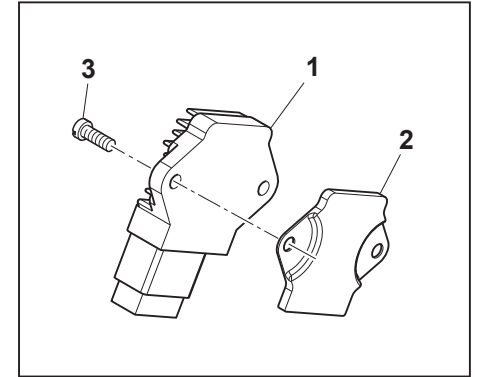



Note Notes Marke Notas	Pos. N. Index Pos.	N. Cod. Code No. Nr. Code Code Nr N. Cod.	Q.tà Q.ty Q.te M.ge C.ad	DENOMINAZIONE	NAME	DESIGNATION	BESHREIBUNG	DENOMINACION
	1	8000B0563	1	REGOLATORE DI TENSIONE	VOLTAGE REGULATOR	RÉGULATEUR DE TENSION	SPANNUNGSREGLER	REGULADOR DE TENSIÓN
	2	8000B1061	1	PIASTRINA DISSIPAZIONE CALORE	HEAT DISSIPATION PLATE	PLAQUETTE	PLÄTTCHEN	PLACA
	3	Z00062728	2	VITE TEF M6x20	FLANGED EXAGON HEAD SCREW M6x20	BOULON DE BRIDE M6x20	FLANSCHENSCHRAUBE M6x20	TORNILLO DE REBORDE M6x20
	4	E000P00814	1	CENTRALINA PROGRAMMATA	PROGRAMMED CONTROL UNIT	BOÏTIER	STEUEREL	CENTRALITA PROGRAMADA
	5	ZA0067997	2	VITE M5x16	BOLT M5x16	VIS M5x16	SCHRAUBE M5x16	TORNILLO M5x16
	6	8000H0822	2	BUSSOLA CON COLLETTTO	FLANGED BUSHING	DOUILLE À BRIDE	FLANSCHBUCHSE	CASQUILLO CON BRIDA
	7	Z00062726	1	VITE TEF M6x14	FLANGED EXAGON HEAD SCREW M6x14	BOULON DE BRIDE M6x14	FLANSCHENSCHRAUBE M6x14	TORNILLO DE REBORDE M6x14
	8	Z00044240	2	DADO	NUT	ECROU	MUTTER	TUERCA
	9	Z00048814	2	ROSETTA	WASHER	RONDELLE	UNTERLEGSCHIEBE	ARANDELA
	10	31150168	1	ROTORE	ROTOR	ROTOR	ROTOR	ROTOR
	11	21210014	1	CHIAVETTA	WOODRUFF KEY	CLÉ	FEDERKEIL	MEMORIA
	12	72020426	1	DADO FLANGIATO	FLANGED NUT	ECROU BRIDE	FLANSCHMUTTER	TUERCA CON BRIDA
	13	72040463	1	ROSETTA	WASHER	RONDELLE	UNTERLEGSCHIEBE	ARANDELA
	14	31170039	1	CANDELA NGK CR8E	SPARK PLUG NGK CR8E	BOUGIE NGK CR8E	ZÜNDKERZE NGK CR8E	BUJÍA NGK CR8E
	15	31020133	1	BOBINA	COIL	BOBINE	ZÜNDSPULE	BOBINA
	16	M000P01984	1	GOMMINO	RUBBER RING	JOINT EN CAOUTCHOUC	GUMMISCHEIBE	GOMA
	17	73131652	1	PIASTRINA	PLATE	PLAQUETTE	PLÄTTCHEN	PLACA
	18	72012186	2	VITE TEF M5x8	FLANGED EXAGON HEAD SCREW M5x8	BOULON DE BRIDE M5x8	FLANSCHENSCHRAUBE M5x8	TORNILLO DE REBORDE M5x8
	19	31140381	1	STATORE	STATOR	STATOR	STATOR	ESTATOR
	20	72010386	3	VITE TEF M6x22	FLANGED EXAGON HEAD SCREW M6x22	BOULON DE BRIDE M6x22	FLANSCHENSCHRAUBE M6x22	TORNILLO DE REBORDE M6x22
	21	72010157	2	VITE PICK UP M6x16	PICK UP M6x16 BOLT	VIS PICK UP M6x16	SCHRAUBE PICK UP M6x16	TORNILLO PICK UP M6x16
	22	73131651	1	PIASTRINA	PLATE	PLAQUETTE	PLÄTTCHEN	PLACA
	23	72010157	1	VITE M6x16	SCREW M6x16	VIS M6x16	SCHRAUBE M6x16	TORNILLO M6x16

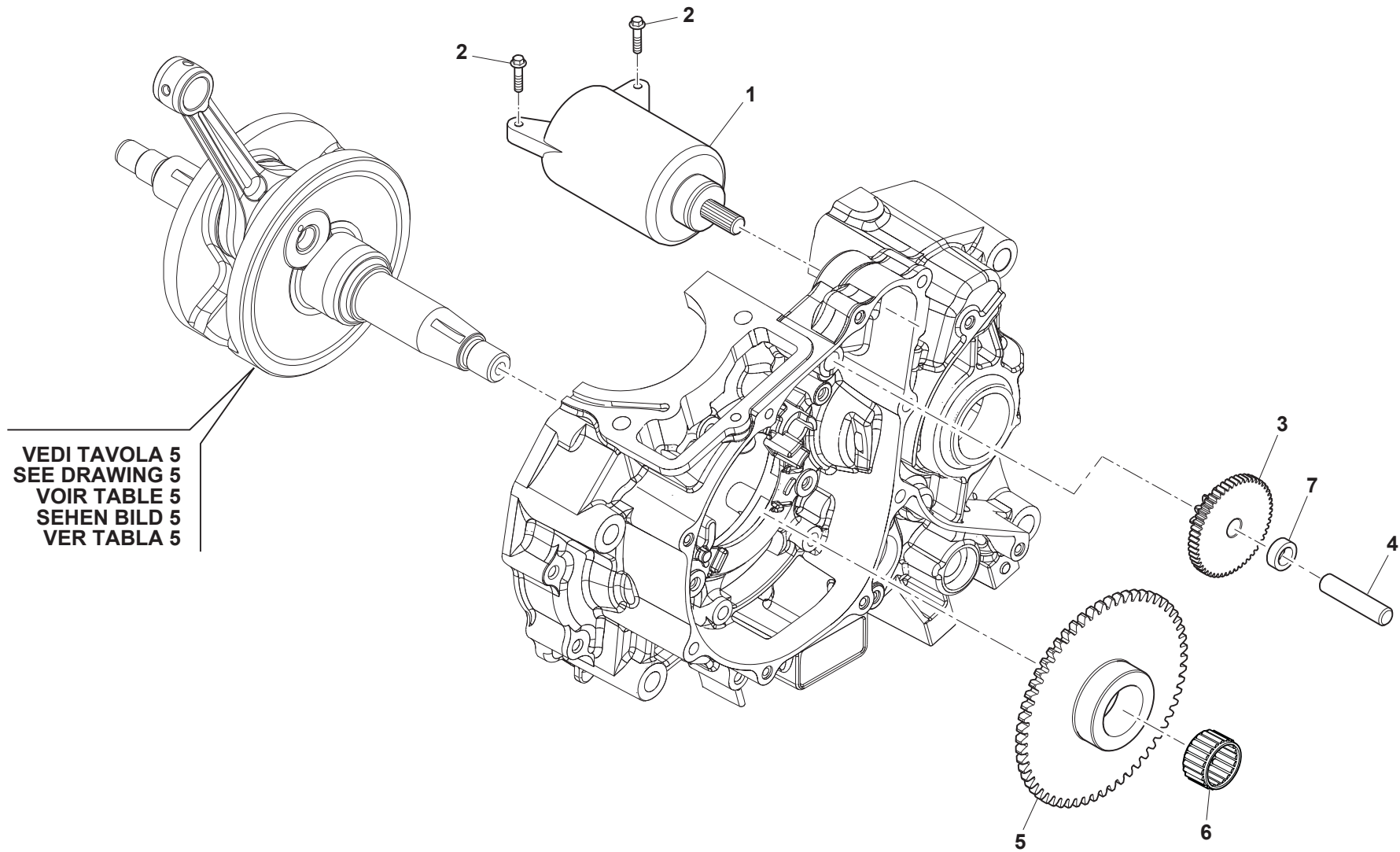

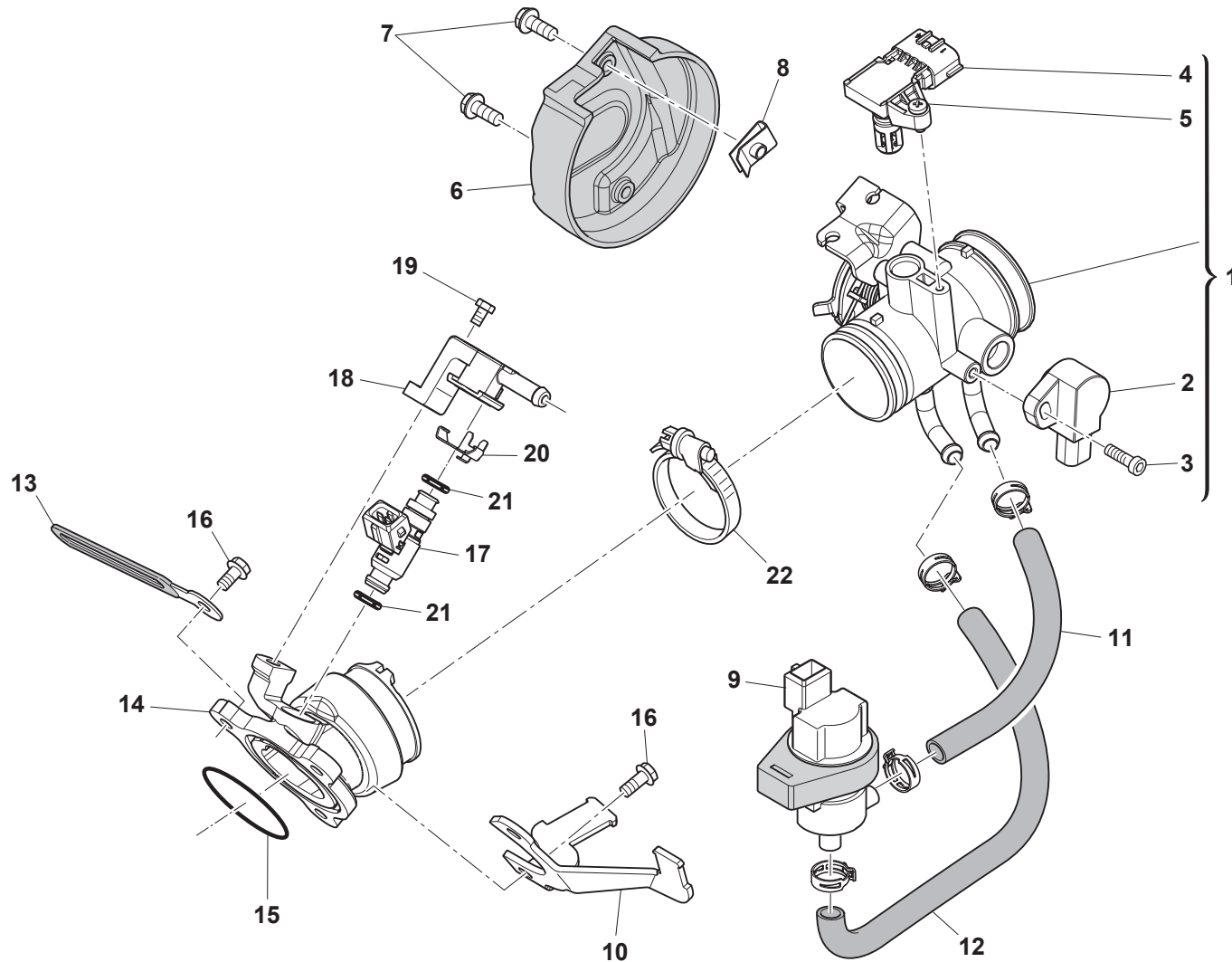



ACE OF SPADES 125 OUTLAW 125

CORPO FARFALLATO - THROTTLE BODY CORP PAPILLON - DROSSELKLAPPENKÖRPER CUERPO OSCILANTE

TAVOLA
DRAWING
TABLE
BILD
TABLA

15

Note Notes Notes Marke Notas	Pos. No. N. Index Pos.	N. Cod. Code No. Nr. Code Code Nr N. Cod.	Q.tà Q.ty Q.te M.ge C.ad	DENOMINAZIONE	NAME	DESIGNATION	BESHREIBUNG	DENOMINACION
	1	M000A00895	1	ASSIEME CORPO FARFALLATO	THROTTLE BODY ASSY	CORPS À PAPILLONS	DROSSELKÖRPER	CUERPO MARIPOSA
	2	31350080	1	SENSORE DI POSIZIONE	POSITION SENSOR	CAPTEUR	SENSOR	SENSOR
	3	72030657	1	VIITE TCIC M4x16	TCIC M4x16 BOLT	VIS TCIC M4x16	SCHRAUBE TCIC M4x16	TORNILLO TCIC M4x16
	4	31350057	1	SENSORE DI PRESSIONE	PRESSURE SENSOR	CAPTEUR DE PRESSION	DRUCKSENSOR	SENSOR PRESIÓN
	5	72030078	1	VITE TEF M5x12	FLANGED EXAGON HEAD SCREW M5x12	BOULON DE BRIDE M5x12	FLANSCHENSCHRAUBE M5x12	TORNILLO DE REBORDE M5x12
	6	F000P00855	1	COPERCHIO	COVER	COUVERCLE	DECKEL	TAPA
	7	Z00067997	2	VITE TEF M5x12	FLANGED EXAGON HEAD SCREW M5x12	BOULON DE BRIDE M5x12	FLANSCHENSCHRAUBE M5x12	TORNILLO DE REBORDE M5x12
	8	8000H2168	1	DADO A GRAFFETTA M5	CLIP NUT M5	ECROU À AGRAFE M5	SICHERUNGSMUTTER M5	TUERCA DE CLIP M5
	9	31350058	1	VALVOLA SOLENOIDE	SOLENOID VALVE	VANNE À SOLÉNOÏDE	MAGNETVENTIL	VÁLVULA SOLENOIDE
	10	F000P01524	1	SUPPORTO VALVOLA SOLENOIDE	SOLENOID VALVE BRACKET	SUPPORT	HALTERUNG	SOPORTE
	11	73090282	1	TUBO INGRESSO	INTAKE HOSE	TUYAU DE REFOULEMENT	VORLAUFROHR	TUBO ALIMENTACIÓN
	12	73090283	1	TUBO USCITA	OUTLET HOSE	TUYAU DE SORTIE	ANSCHLUSSROHR	TUBO SALIDA
	13	8000A1792	1	FASCETTA	CLAMP	COLLIER	SHELLE	ABRAZADERA
	14	M000P00734	1	RACCORDO CORPO FARFALLATO	THROTTLE BODY UNION	RACCORD CORPS À PAPILLONS	ANSCHLUSS DROSSELKÖRPER	RACOR CUERPO DE MARIPOSA
	15	M000P01454	1	ANELLO OR	O-RING	JOINT TORIQUE	O-RING	JUNTA TORICA
	16	Z00062728	3	VITE TEF M6x20	FLANGED EXAGON HEAD SCREW M6x20	BOULON DE BRIDE M6x20	SCHRAUBE M6x20	TORNILLO M6x20
	17	F000P00850	1	INIETTORE	INJECTOR	INJECTEUR	EINSPRITZDÜSE	INYECTOR
	18	F000P00851	1	CAPPUCCIO INIETTORE	INJECTOR CAP	CAPUCHON	KAPPE	CAPUCHÓN
	19	Z00062726	1	VITE TEF M6x14	FLANGED EXAGON HEAD SCREW M6x14	BOULON DE BRIDE M6x14	FLANSCHENSCHRAUBE M6x14	TORNILLO DE REBORDE M6x14
	20	F000P00852	1	CLIP	CLIP	COLLIER	SHELLE	ABRAZADERA
	21	F000P01472	2	ANELLO OR	O-RING	JOINT TORIQUE	O-RING	JUNTA TORICA
	22	8H0099475	1	FASCETTA	CLAMP	COLLIER	SHELLE	ABRAZADERA

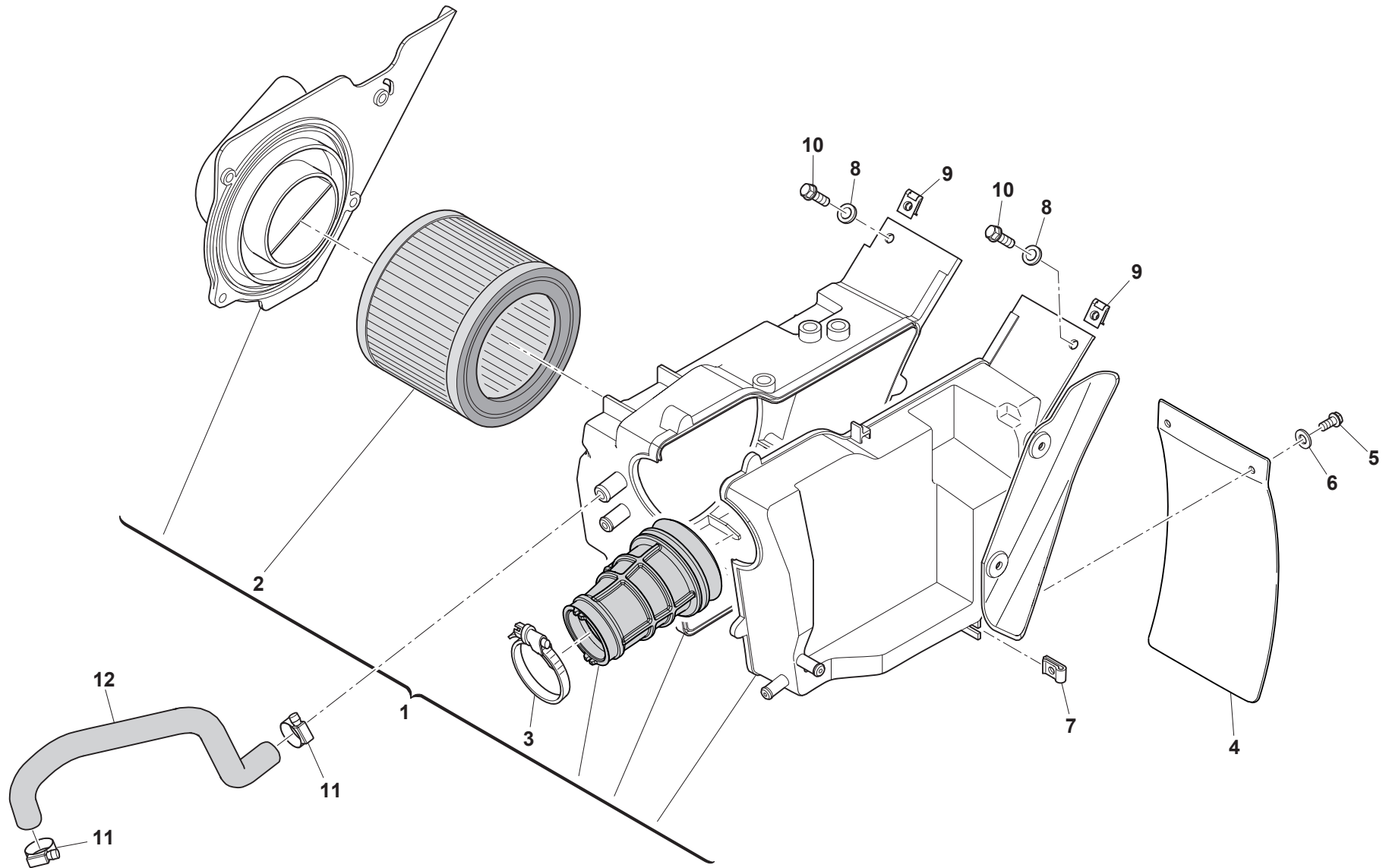



ACE OF SPADES 125
OUTLAW 125

FILTRO ARIA - AIR FILTER
FILTRE AIRE - LUFTFILTER
FILTRO DE AIRE

TAVOLA
DRAWING
TABLE
BILD
TABLA

16

Note Notes Notes Marke Notas	Pos. No. Index Pos.	N. Cod. Code No. Nr. Code Code Nr N. Cod.	Q.tà Q.ty Q.te M.ge C.ad	DENOMINAZIONE	NAME	DESIGNATION	BESHREIBUNG	DENOMINACION
	1	F000A03505	1	SCATOLA FILTRO ARIA	AIR FILTER BOX	BOÎTIER DE FILTRE À AIR	LUFTFILTERGEHÄUSE	CAJA FILTRO AIRE
	2	18130045	1	FILTRO ARIA	AIR FILTER	FILTRE À AIR	LUFTFILTER	FILTRO AIRE
	3	18170097	1	FASCETTA METALLICA TJBC 40-60	METALLIC CLIP TJBC 40-60	COLLIERT JBC 40-60	SCHELLE TJBC 40-60	ABRAZADERA TJBC 40-60
	4	73021054	1	PARASPRUZZI	INTERNAL REAR MUDGUARD	GARDE-BOUE ARRIÈRE INTÉRIEUR	HINTERRADKOTFLÜGEL INNEN	GUARDABARROS TRASERO INTERNO
	5	Z00067997	3	VITE TEF M5x12	FLANGED EXAGON HEAD SCREW M5x12	BOULON DE BRIDE M5x12	FLANSCHENSCHRAUBE M5x12	TORNILLO DE REBORDE M5x12
	6	62ND15548	3	ROSETTA	WASHER	RONDELLE	UNTERLEGSCHIEBE	ARANDELA
	7	U00055134	2	DADO A GRAFFETTA M5	CLIP NUT M5	ECROU À AGRAFE M5	SICHERUNGSMUTTER M5	TUERCA DE CLIP M5
	8	Z00021535	2	ROSETTA	WASHER	RONDELLE	UNTERLEGSCHIEBE	ARANDELA
	9	U00046893	2	DADO A GRAFFETTA M6	CLIP NUT M6	ECROU À AGRAFE M6	SICHERUNGSMUTTER M6	TUERCA DE CLIP M6
	10	Z00062727	2	VITE TEF M6x16	FLANGED EXAGON HEAD SCREW M6x16	BOULON DE BRIDE M6x16	FLANSCHENSCHRAUBE M6x16	TORNILLO DE REBORDE M6x16
	11	8A0092249	2	FASCETTA	CLAMP	COLLIER	SCHELLE	ABRAZADERA
	12	F000P03790	1	TUBO SFIATO OLIO	OIL BREATHER PIPE	TUYAU DE PURGE HUILE	ÖLENTLÜFTUNGSROHR	TUBO RESPIRADERO ACEITE

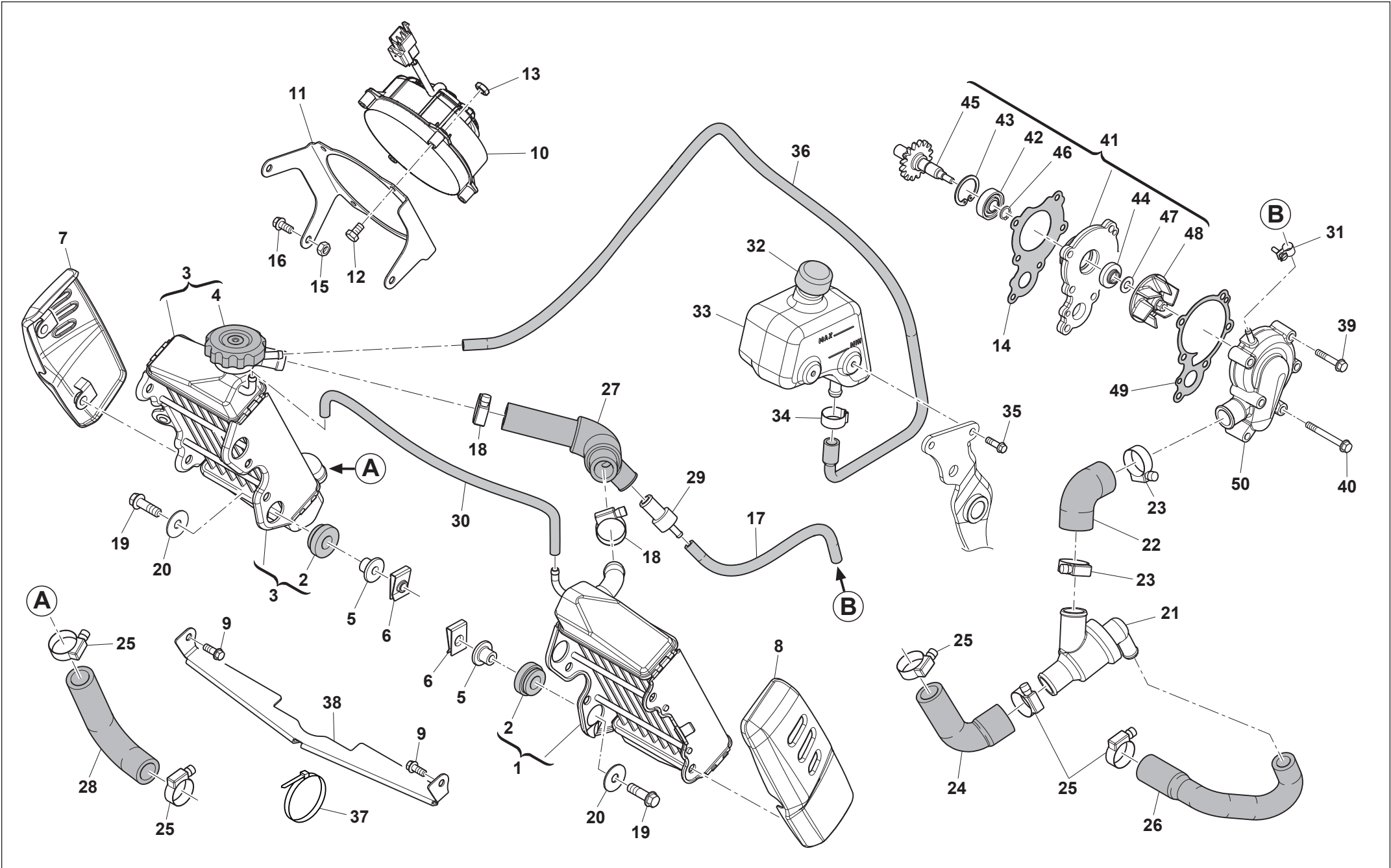



Note Notes Notes Marke Notas	Pos. No. N. Index Pos.	N. Cod. Code No. Nr. Code Code Nr N. Cod.	Q.tà Q.ty Q.te M.ge C.ad	DENOMINAZIONE	NAME	DESIGNATION	BESHREIBUNG	DENOMINACION
	1	F000P03423	1	RADIATORE SINISTRO	L.H. RADIATOR	RADIATEUR GAUCHE	KÜHLER LINKS	RADIADOR IZQUIERDO
	2	F000P00025	4	GOMMINO	RUBBER RING	JOINT EN CAOUTCHOUC	GUMMISCHEIBE	GOMA
	3	F000A03422	1	RADIATORE DESTRO	RIGHT RADIATOR	RADIATEUR DROITE	KÜHLER RECHTS	RADIADOR DERECHO
	4	F000P03513	1	TAPPO	PLUG	BOUCHON	STOPFEN	TAPON
	5	8000B0263	4	DISTANZIALE	SPACER	ENTRETOISE	ABSTANDHALTER	DISTANCIADOR
	6	U00046893	4	DADO A GRAFFETTA M6	CLIP NUT M6	ECROU À AGRAFE M6	SICHERUNGSMUTTER M6	TUERCA DE CLIP M6
	7	F000P03651	1	PROTEZIONE RADIATORE DESTRA	COVER RADIATOR R.H.	PROTECTION RADIATEUR DROIT	KUEHLERSCHUTZ, RECHTS	PROTECCION RADIADOR DERECHO
	8	FA00P03651	1	PROTEZIONE RADIATORE SINISTRA	COVER RADIATOR L.H.	PROTECTION RADIATEUR GAUCHE	KUEHLERSCHUTZ, LINKS	PROTECCION RADIADOR IZQUERDO
	9	ZH0067545	2	VITE M6x12	SCREW M6x12	VIS M6x12	SCHRAUBE M6x12	TORNILLO M6x12
	10	8000A7715	1	ELETTROVENTOLA	ELECTRIC FAN	ELECTRO-VENTILATEUR	KÜHLGEBLÄSE	ELECTROVENTILADOR
	11	F000P03426	1	SUPPORTO	SUPPORT	SUPPORT	HALTERUNG	SOPORTE
	12	60ND01030	4	VITE TE M4x25	HEXAGON SOCKET-HEAD BOLT M4x25	VIS M4x25	SCHRAUBE M4x25	TORNILLO M4x25
	13	Z00040717	4	DADO AUTOBLOCCANTE M4	SELF-LOCKING NUT M4	ECROU AUTOBLOQUANT M4	SELBSTSICHERNDE MUTTER M4	TUERCA AUTOBLOCCANTE M4
	14	72130621	1	GUARNIZIONE BASE POMPA ACQUA	BASE WATER PUMP GASKET	JOINT BASE POMPE À EAU	DICHTUNG BODEN WASSERPUMPE	JUNTA BASE BOMBA AGUA
	15	Z00044240	1	DADO AUTOBLOCCANTE M6	SELF-LOCKING NUT M6	ECROU AUTOBLOQUANT M6	SELBSTSICHERNDE MUTTER M6	TUERCA AUTOBLOCCANTE M6
	16	ZH0067545	3	VITE M6x12	SCREW M6x12	VIS M6x12	SCHRAUBE M6x12	TORNILLO M6x12
	17	FH00P03205	1	TUBO L=175	PIPE L=175	TUBE L=175	ROHR L=175	TUBO L=175
	18	8C00H1981	2	FASCETTA	CLAMP	COLLIER	SHELLE	ABRAZADERA
	19	Z00062729	4	VITE TEF M6x25	FLANGED EXAGON HEAD SCREW M6x25	BOULON DE BRIDE M6x25	FLANSCHENSCHRAUBE M6x25	TORNILLO DE REBORDE M6x25
	20	Z00059801	4	ROSETTA	WASHER	RONDELLE	UNTERLEGSCHIEBE	ARANDELA
	21	F000P03478	1	TERMOSTATO	THERMOSTAT	THERMOSTAT	THERMOSTAT	TERMOSTATO
	22	F000P03417	1	TUBO POMPA ACQUA-RADIATORE	PIPE	TUBE	ROHR	TUBO
	23	8B0099475	3	FASCETTA HOP8-16/27	CLAMP HOP8-16/27	COLLIER HOP8-16/27	SHELLE HOP8-16/27	ABRAZADERA HOP8-16/27
	24	F000P03418	1	TUBO TERMOSTATO-RADIATORI	THERMOSTAT-RADIATOR PIPE	TUYAU THERMOSTAT-RADIATEURS	ROHR THERMOSTAT-KÜHLER	TUBO TERMOSTATO-RADIADORES
	25	8A0099475	7	FASCETTA HOP8-10/22	CLAMP HOP8-10/22	COLLIER HOP8-10/22	SHELLE HOP8-10/22	ABRAZADERA HOP8-10/22
	26	F000P03419	1	TUBO TERMOSTATO-CARTER	PIPE	TUBE	ROHR	TUBO
	27	F000P03902	1	TUBO COLLEGAMENTO RADIATORI	RADIATOR CONNECTING PIPE	TUYAU RACCORDEMENT RADIATEURS	VERBINDUNGSROHR KÜHLER	TUBO CONEXIÓN RADIADORES
	28	F000P03421	1	TUBO RADIATORE-CARTER	PIPE	TUBE	ROHR	TUBO
	29	F000P03901	1	RIDUZIONE	UNION	RACCORD	ANSCHLUSS	RACOR
	30	FC00P03205	1	TUBO L=230	PIPE L=230	TUBE L=230	ROHR L=230	TUBO L=230
	31	8B00H1981	2	FASCETTA	CLAMP	COLLIER	SHELLE	ABRAZADERA
	32	800040427	1	TAPPO	PLUG	BOUCHON	STOPFEN	TAPON
	33	F000P03401	1	SERBATOIO ESPANSIONE	EXPANSION TANK	RÉSERVOIR D'EXPANSION	AUSDEHNUNGSGEFÄß	DEPÓSITO EXPANSIÓN

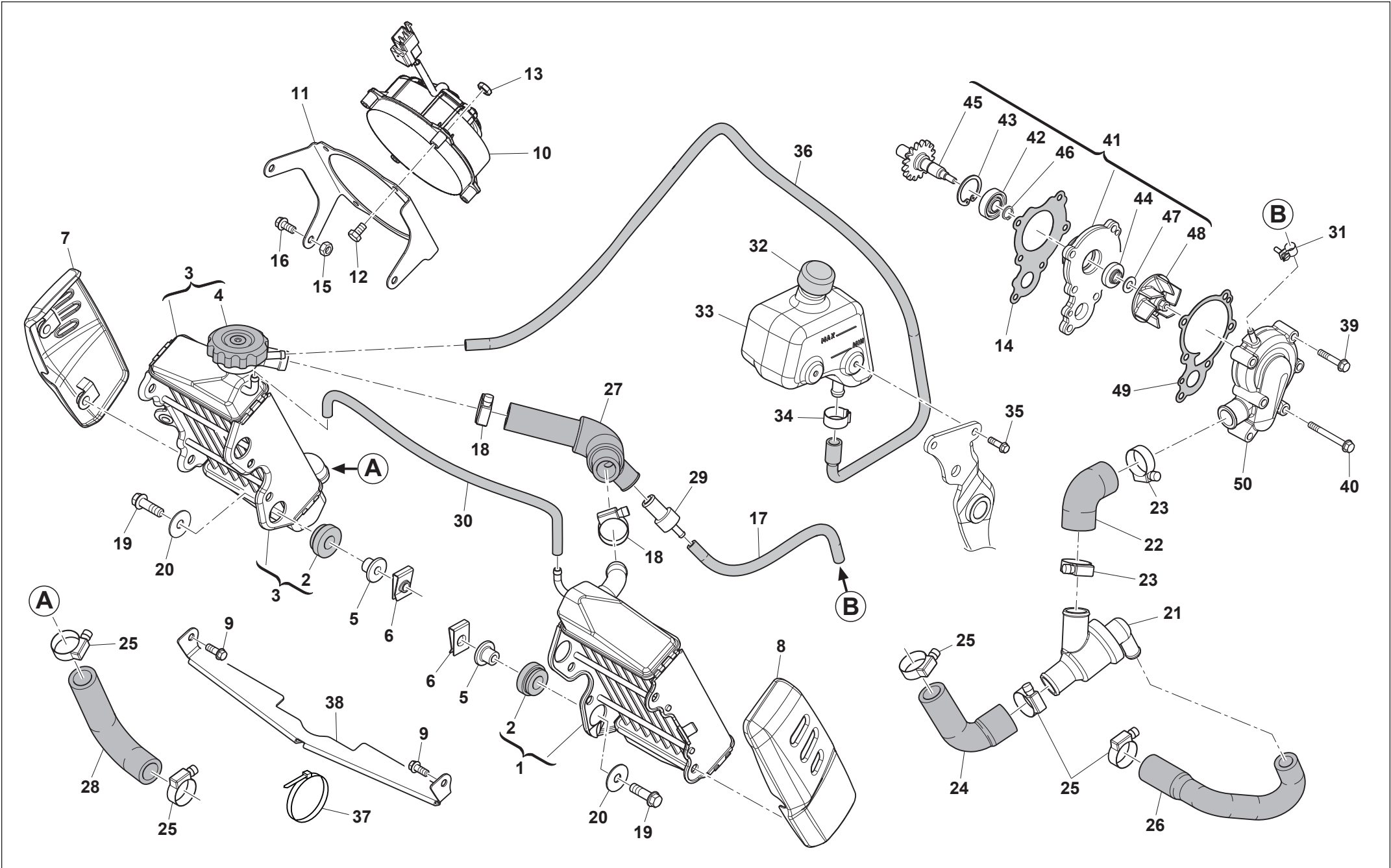

Note Notes Marke Notas	Pos. No. Index Pos.	N. Cod. Code No. Nr. Code Code Nr N. Cod.	Q.tà Q.ty Q.te M.ge C.ad	DENOMINAZIONE	NAME	DESIGNATION	BESHREIBUNG	DENOMINACION
	34	8B0091687	1	FASCETTA	CLAMP	COLLIER	SHELLE	ABRAZADERA
	35	ZE0067997	2	VITE TEF M5x10	FLANGED EXAGON HEAD SCREW M5x10	BOULON DE BRIDE M5x10	FLANSCHENSCHRAUBE M5x10	TORNILLO DE REBORDE M5x10
	36	8000A1281	1	TUBO RADIATORE-VASO DI ESPANSIONE	PIPE	TUBE	ROHR	TUBO
	37	F000P04023	1	FASCETTA	CLAMP	COLLIER	SHELLE	ABRAZADERA
	38	F000P03862	1	DEFLETTORE	DEFLECTOR	DEFLECTEUR	DEFLEKTOR	DEFLECTOR
	39	72012184	4	VITE TEF M5x38	FLANGED EXAGON HEAD SCREW M5x38	BOULON DE BRIDE M5x38	FLANSCHENSCHRAUBE M5x38	TORNILLO DE REBORDE M5x38
	40	72012185	2	VITE TEF M5x48	FLANGED EXAGON HEAD SCREW M5x48	BOULON DE BRIDE M5x48	FLANSCHENSCHRAUBE M5x48	TORNILLO DE REBORDE M5x48
	41	76220007	1	POMPA ACQUA COMPLETA	COMPLETE WATER PUMP	POMPE À EAU COMPLÈTE	WASSERPUMPE KOMPLETT	BOMBA AGUA COMPLETA
	42	17230008	1	CUSCINETTO 6000 26x10x8	BEARING 6000 26x10x8	ROULEMENT 6000 26x10x8	LAGER 6000 26x10x8	COJINETE 6000 26x10x8
	43	72080136	1	ANELLO DI FERMO INTERNO	INNER RETAINING RING	BAGUE D'ARRET	SICHERUNGSRING	ANILLO DE RETENCION
	44	8000A7324	1	ANELLO CORCOS 22x9x8,6	CORCOS 22x9x8,6 RING	BAGUE CORCOS 22x9x8,6	RING CORCOS 22x9x8,6	ANILLO CORCOS 22x9x8,6
	45	17220006	1	ALBERO POMPA ACQUA	WATER PUMP SHAFT	ARBRE POMPE A EAU	WELLE WASSERPUMPE	EJE BOMBA AGUA
	46	72080135	1	ANELLO DI FERMO	RETAINING RING	BAGUE D'ARRET	SICHERUNGSRING	ANILLO DE RETENCION
	47	17030009	1	ROSETTA	WASHER	RONDELLE	UNTERLEGSCHIEBE	ARANDELA
	48	17230006	1	GIRANTE POMPA ACQUA	WATER PUMP IMPELLER	ROTOR POMPE À EAU	WASSERPUMPE LAUFRAD	BOMBA AGUA RODETE
	49	72130625	1	GUARNIZIONE COPERCHIO POMPA	PUMP COVER GASKET	JOINT COUVERCLE POMPE	DICHTUNG DECKEL PUMPE	JUNTA TAPA BOMBA
	50	14140035	1	COPERCHIO POMPA ACQUA	WATER PUMP COVER	COUVERCLE POMPE À EAU	DECKEL WASSERPUMPE	TAPA BOMBA AGUA

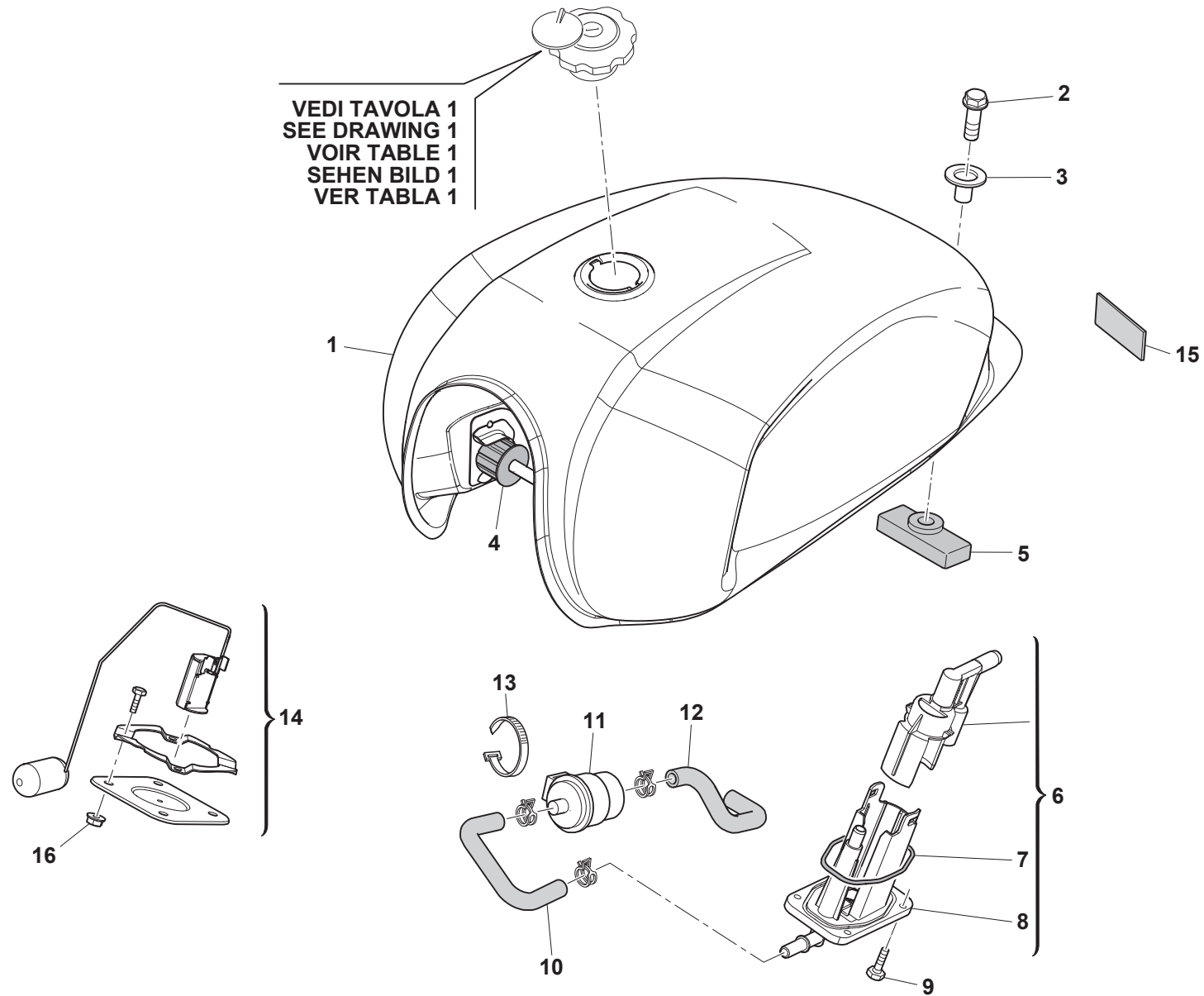



ACE OF SPADES 125 OUTLAW 125

SERBATOIO CARBURANTE - FUEL TANK RESERVOIR CARBURANT - KRAFTSTOFFBEHALTER DEPOSITO GASOLINA

TAVOLA
DRAWING
TABLE
BILD
TABLA

18

Note Notes Marke Notas	Pos. No. Index Pos.	N. Cod. Code No. Nr. Code Code Nr N. Cod.	Q.tà Q.ty Q.te M.ge C.ad	DENOMINAZIONE	NAME	DESIGNATION	BESHREIBUNG	DENOMINACION
ACE OF SPACE	1	F0F0A02293	1	ASS. SERBATOIO CARBURANTE	FUEL TANK ASSY	RESERVOIR DE CARBURANT COMPLET	KRAFTSTOFFTANK KOMPLETT	DEPOSITO COMBUSTIBLE COMPLETO
OUTLAW	1	F0G0A02293	1	ASS. SERBATOIO CARBURANTE	FUEL TANK ASSY	RESERVOIR DE CARBURANT COMPLET	KRAFTSTOFFTANK KOMPLETT	DEPOSITO COMBUSTIBLE COMPLETO
	2	72011245	1	VITE TEF M8x30	FLANGED EXAGON HEAD SCREW M8x30	BOULON DE BRIDE M8x30	FLANSCHENSCHRAUBE M8x30	TORNILLO DE REBORDE M8x30
	3	70120233	1	BUSSOLA	BUSHING	DOUILLE	BUCHSE	CASQUILLO
	4	F000P02483	2	TAMPONE LATERALE SERBATOIO	FRONT DAMPING MAT	TAMPON LATÉRALE	PUFFER SEITLICH	TACO LATERAL
	5	F000P02482	1	TAMPONE POSTERIORE SERBATOIO	REAR DAMPING MAT	TAMPON ARRIÈRE	PUFFER HINTEN	TACO TRASERO
	6	F000A03506	1	POMPA BENZINA	FUEL PUMP	POMPE À CARBURANT	BENZINPUMPE	BOMBA GASOLINA
	7	31350081	1	GUARNIZIONE POMPA BENZINA	FUEL PUMP GASKET	JOINT POMPE DE CARBURANT	DICHTUNG PUMPE	JUNTA BOMBA COMBUSTIBLE
	8	31350083	1	PIASTRA METALLICA	METALLIC PLATE	PLAQUE	PLATTE	PLACA
	9	72030657	4	VITE M4x16	BOLT M4x16	VIS M4x16	SCHRAUBE M4x16	TORNILLO M4x16
	10	F000A00761	1	TUBO MANDATA BENZINA CON CLIPS	PUMP- FUEL FILTER HOSE WITH CLIPS	TUYAU DE REFOULEMENT	VORLAUFROHR	TUBO ALIMENTACIÓN
	11	F000P00915	1	FILTRO BENZINA	FUEL FILTER	FILTRE DE CARBURANT	BENZINFILTER	FILTRO COMBUSTIBLE
	12	F000P03456	1	TUBO FILTRO-INIETTORE CON CLIPS	FUEL FILTER-INJECTOR HOSE WITH CLIPS	TUBE FILTRE-INJECTEUR	ROHR FILTER-EINSPRITZDÜSE	TUBO FILTRO-INYECTOR
	13	8D0091687	1	FASCETTA	CLAMP	COLLIER	SHELLE	ABRAZADERA
	14	F000A02332	1	SENSORE LIVELLO BENZINA	FUEL SENDER ASSY	CAPTEUR	SENSOR	SENSOR
	15	800037140	1	ANTIVIBRANTE ADESIVO	SILENT-BLOCK ADHESIVE	ADHÉSIF ANTIVIBRATION	AUFKLEBER SCHWINGUNGSDAMFER	ANTIVIBRADOR ADHESIVO
	16	72020178	4	DADO M6	NUT M6	ECROU M6	MUTTER M6	TUERCA M6

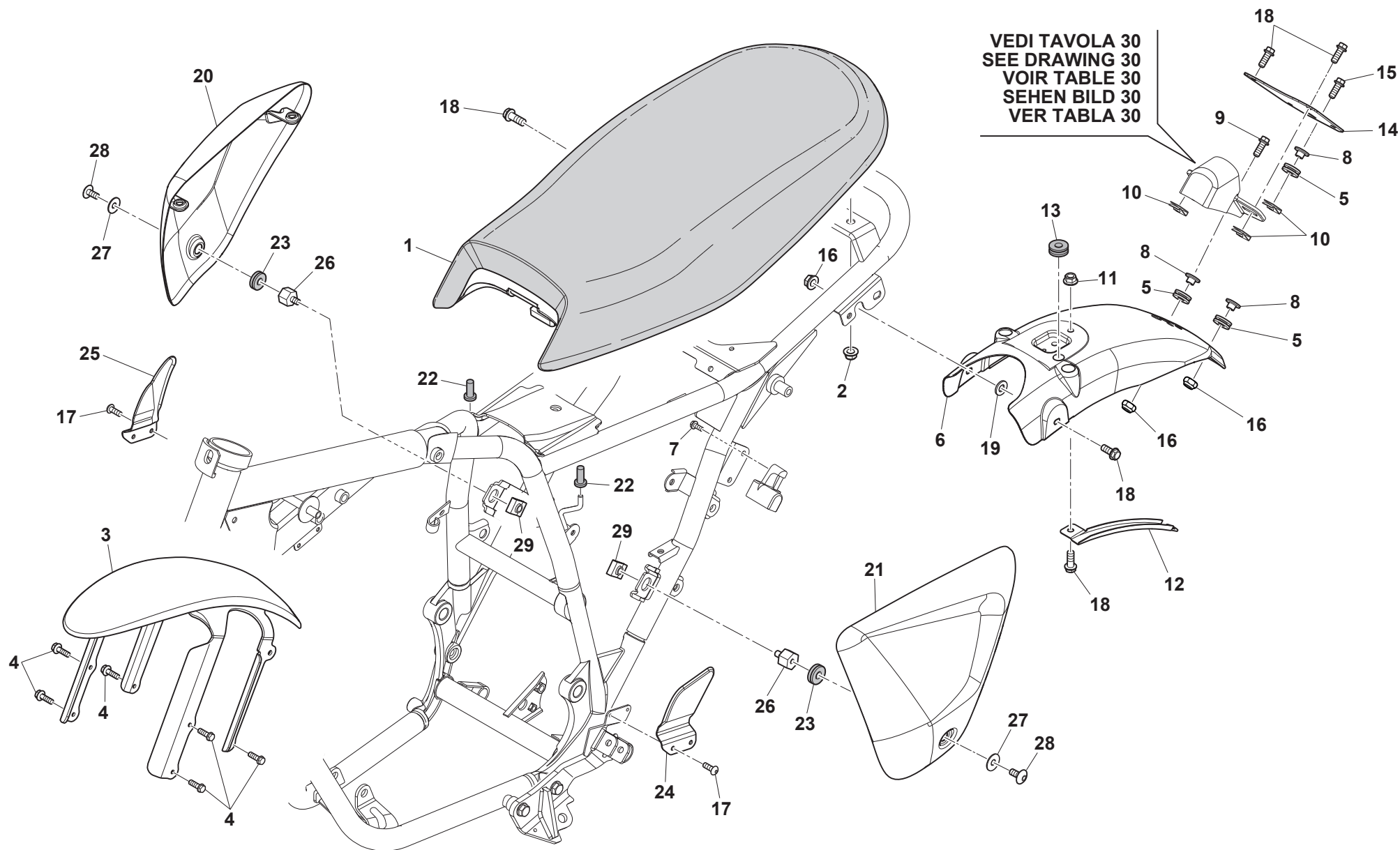



ACE OF SPADES 125 OUTLAW 125

**PANNELLI, PARAFANGHI, SELLA - PANEL, FENDERS, SEAT
PANNEAU, GARDE-BOUES, SIEGE - STREIFEN, KOTFLUGEL, SATTEL
PANELO, GUARDABARROS, SILLIN**

TAVOLA
DRAWING
TABLE
BILD
TABLA

19

Note Notes Notas	Pos. No. N. Index Pos.	N. Cod. Code No. Nr. Code Code Nr N. Cod.	Q.tà Q.ty Q.te M.ge C.ad	DENOMINAZIONE	NAME	DESIGNATION	BESHREIBUNG	DENOMINACION
ACE OF SPADES	1	FA00A03191	1	SELLA	SADDLE	SELLE	SITZBANK	ASIENTO
OUTLAW	1	F000A03191	1	SELLA	SADDLE	SELLE	SITZBANK	ASIENTO
	2	Y00043928	2	DADO FRENATO M8x12	SELF-LOCKING NUT M8x12	ECROU AUTOBLOQUANT M8x12	SELBSTSICHERNDE MUTTER M8x12	TUERCA AUTOBLOCANTE M8x12
	3	F000P00285	1	PARAFANGO ANTERIORE	FRONT MUDGUARD	GARDE-BOUE AVANT	VORDERRADKOTFLÜGEL	GUARDABARROS DELANTERO
	4	Z00067997	6	VITE TEF M5x12	FLANGED EXAGON HEAD SCREW M5x12	BOULON DE BRIDE M5x12	FLANSCHENSCHRAUBE M5x12	TORNILLO DE REBORDE M5x12
	5	800041862	4	GOMMINO ANTIVIBRANTE	SILENT-BLOCK	ANTIVIBRATION	SCHWINGUNGSDAMFER	ANTIVIBRADOR
	6	F000P02764	1	PARAFANGO POSTERIORE	REAR MUDGUARD	GARDE-BOUE ARRIÈRE	HINTERRADKOTFLÜGEL	GUARDABARROS TRASERO
	7	ZH0067545	2	VITE TEF M6x12	FLANGED EXAGON HEAD SCREW M6x12	BOULON DE BRIDE M6x12	FLANSCHENSCHRAUBE M6x12	TORNILLO DE REBORDE M6x12
	8	8000B2799	3	DISTANZIALE CON COLLETTA	FLANGED SPACER	ENTRETOISE A BRIDE	ABSTANDHALTER	DISTANCIADOR EMBRIDADO
	9	Z00062728	3	VITE TEF M6x20	FLANGED EXAGON HEAD SCREW M6x20	BOULON DE BRIDE M6x20	FLANSCHENSCHRAUBE M6x20	TORNILLO DE REBORDE M6x20
	10	Z00061313	2	DADO A GRAFFETTA M6X1	CLIP NUT M6X1	ECROU À AGRAFE M6X1	SICHERUNGSMUTTER M6X1	TUERCA DE CLIP M6X1
	11	Z00044240	2	DADO AUTOBLOCCANTE	SELF-LOCKING NUT	ECROU AUTOBLOQUANT	SELBSTSICHERNDE MUTTER	TUERCA AUTOBLOCANTE
	12	73032132	1	PIASTRINA	PLATE	PLAQUETTE	PLÄTTCHEN	PLACA
	13	73012329	2	GOMMINO PASSAGGIO CAVI	RUBBER SLEEVE	JOINT EN CAOUTCHOUC	GUMMISCHEIBE	GOMA
	14	F000P02747	1	SUPPORTO TARGA	LICENCE PLATE SUPPORT	SUPPORT PLAQUE D'IMM.	KENNZEICHENHALTERUNG	SOPORTE MATRÍCULA
	15	Z00062729	1	VITE TEF M6x25	FLANGED EXAGON HEAD SCREW M6x25	BOULON DE BRIDE M6x25	FLANSCHENSCHRAUBE M6x25	TORNILLO DE REBORDE M6x25
	16	Z00061313	10	DADO M6	NUT M6	ECROU M6	MUTTER M6	TUERCA M6
	17	ZA0059572	4	VITE TBEI M5x12	BOLT TBEI M5x12	VIS TBEI M5x12	SCHRAUBE TBEI M5x12	TORNILLO TBEI M5x12
	18	ZH0067545	6	VITE TEF M6x12	FLANGED EXAGON HEAD SCREW M6x12	BOULON DE BRIDE M6x12	FLANSCHENSCHRAUBE M6x12	TORNILLO DE REBORDE M6x12
	19	62ND15504	2	ROSETTA	WASHER	RONDELLE	UNTERLEGSCHEIBE	ARANDELA
	20	F000P02301	1	PANNELLO DESTRO	RIGHT SIDE PANEL	PANNEAU DROITE	PANEEL RECHTS	PANEL DERECHO
	21	F000P02302	1	PANNELLO SINISTRO	LEFT SIDE PANEL	PANNEAU GAUCHE	PANEEL LINKS	PANEL IZQUIERDO
	22	73012510	4	GOMMINO ANTIVIBRANTE	SILENT-BLOCK	ANTIVIBRATION	SCHWINGUNGSDAMFER	ANTIVIBRADOR
	23	F000P02917	2	GOMMINO ANTIVIBRANTE	SILENT-BLOCK	ANTIVIBRATION	SCHWINGUNGSDAMFER	ANTIVIBRADOR
	24	F000P03707	1	PROTEZIONE SINISTRA	L.H. PROTECTION	PROTECTION GAUCHE	SCHUTZ LINKS	PROTECCIÓN IZQ.
	25	F000P03708	1	PROTEZIONE DESTRA	R.H. PROTECTION	PROTECTION DROITE	SCHUTZ RECHTS	PROTECCIÓN DER.
	26	F000P02610	2	DISTANZIALE	SPACER	ENTRETOISE	ABSTANDHALTER	DISTANCIADOR
	27	ZA0069429	2	BUSSOLA Ø9-Ø7-SP8	BUSHING Ø9-Ø7-SP8	DOUILLE Ø9-Ø7-SP8	BUCHSE Ø9-Ø7-SP8	CASQUILLO Ø9-Ø7-SP8
	28	Z0C055703	2	VITE M6	BOLT M6	VIS M6	SCHRAUBE M6	TORNILLO M6
	29	U00046893	2	DADO A GRAFFETTA	CLIP NUT	ECROU À AGRAFE	SICHERUNGSMUTTER	TUERCA DE CLIP

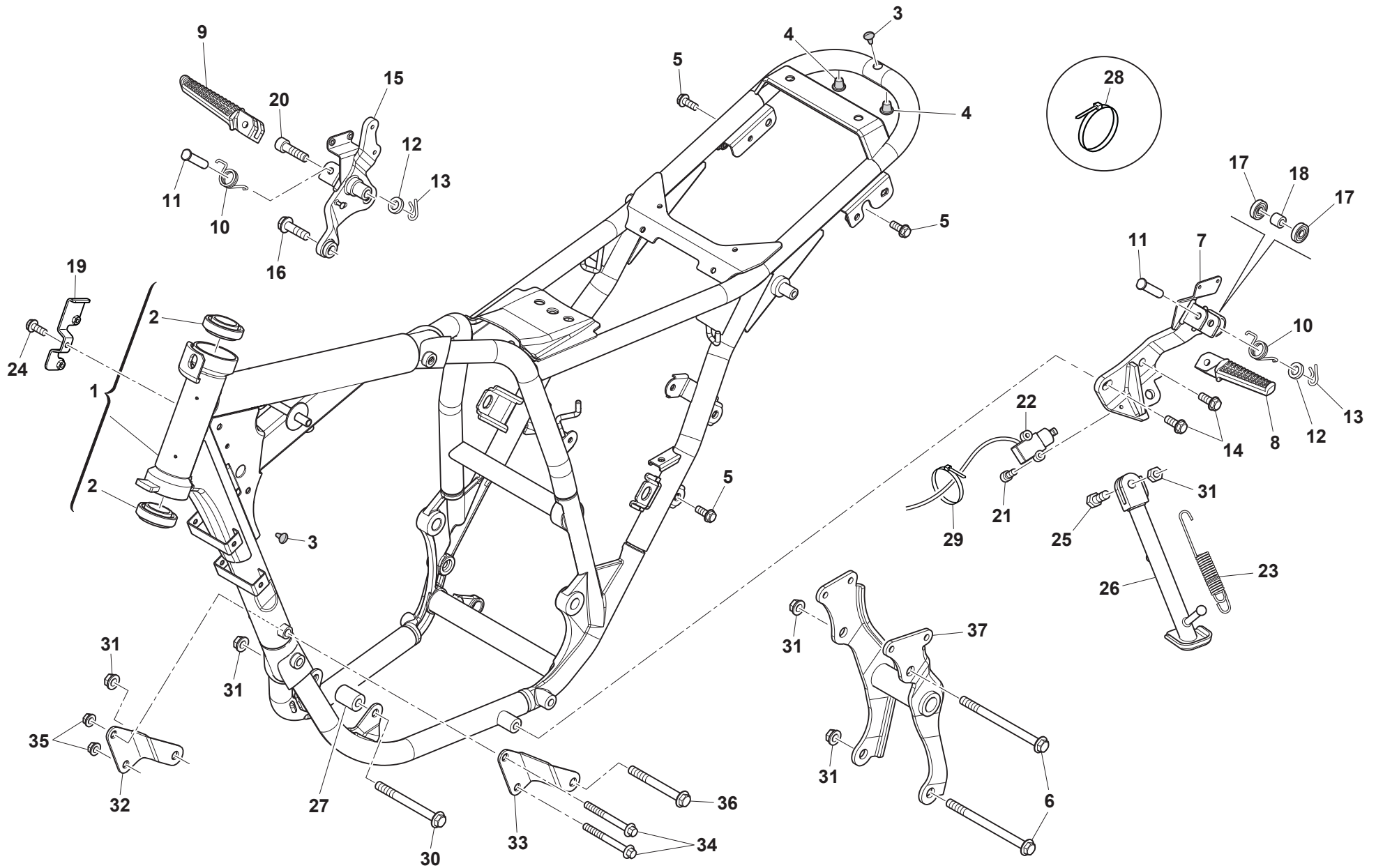



ACE OF SPADES 125 OUTLAW 125

TELAIO, PEDANE - FRAME, FOOT RESTS CADRE, REPOSE PIEDS - RAHMEN, FUSSBRETT BASTIDOR, REPOSAPIES

TAVOLA
DRAWING
TABLE
BILD
TABLA

20

Note Notes Notes Marke Notas	Pos. No. N. Index Pos.	N. Cod. Code No. Nr. Code Code Nr N. Cod.	Q.tà Q.ty Q.te M.ge C.ad	DENOMINAZIONE	NAME	DESIGNATION	BESHREIBUNG	DENOMINACION
	1	F000A03492	1	TELAIO CON CUSCINETTI	FRAME WITH BEARINGS	CHÂSSIS AVEC ROULEMENTS	RAHMEN MIT LAGERN	CHASIS CON COJINETES
	2	800087243	2	CUSCINETTO A RULLI CONICI	TAPERED ROLLER BEARING	ROULEMENT À ROULEAUX CONIQUES	KEGELROLLENLAGER	COJINETE DE RODILLOS CÓNICOS
	3	800058394	3	TAMPONE IN GOMMA	RUBBER BUFFER	TAMPON	PUFFER	TACO
	4	F000P01119	2	TAMPONE IN GOMMA	RUBBER BUFFER	TAMPON	PUFFER	TACO
	5	Z00069056	2	VITE TEF M8x20	FLANGED EXAGON HEAD SCREW M8x20	BOULON DE BRIDE M8x20	FLANSCHENSCHRAUBE M8x20	TORNILLO DE REBORDE M8x20
	6	8U0069138	1	VITE TEF M10x110	SCREW M10x110	BOULON DE BRIDE M10x110	FLANSCHENSCHRAUBE M10x110	TORNILLO DE REBORDE M10x110
	7	F000A03783	1	SUPPORTO PEDANA SINISTRA	L.H. FOOTREST SUPPORT	SUPPORT REPOSE-PIEDS GAUCHE	HALTERUNG FUßRASTE LINKS	SOPORTE ESTRIBO IZQUIERDA
	8	F000P00698	1	PEDANA SINISTRA	L.H. FOOTREST	REPOSE-PIEDS GAUCHE	FUßRASTE LINKS	ESTRIBO IZQUIERDA
	9	F000P00699	1	PEDANA DESTRA	R.H. FOOTREST	REPOSE-PIEDS DROITE	FUßRASTE RECHTS	ESTRIBO DERECHA
	10	F000P00822	2	MOLLA PEDANA SINISTRA	SPRING	RESSORT	FEDER	MUELLE
	11	F000P00823	2	PERNO	PIN	AXE	BOLZEN	EJE
	12	Z00056377	2	ROSETTA	WASHER	RONDELLE	UNTERLEGSCHIEBE	ARANDELA
	13	64ND20068	2	COPIGLIA	SPLIT PIN	GOUPILLE	SPLINT	PASADOR
	14	ZG0062797	2	VITE TEF M10x22	FLANGED EXAGON HEAD SCREW M10x22	BOULON DE BRIDE M10x22	FLANSCHENSCHRAUBE M10x22	TORNILLO DE REBORDE M10x22
	15	F000A00446	1	SUPPORTO PEDANA DESTRA	R.H. FOOTREST SUPPORT	SUPPORT REPOSE-PIEDS DROITE	HALTERUNG FUßRASTE RECHTS	SOPORTE ESTRIBO DERECHA
	16	ZF0062797	1	VITE TEF M10x30	FLANGED EXAGON HEAD SCREW M10x30	BOULON DE BRIDE M10x30	FLANSCHENSCHRAUBE M10x30	TORNILLO DE REBORDE M10x30
	17	70090215	2	CUSCINETTO 6900	BEARING 6900	ROULEMENT 6900	LAGER 6900	COJINETE 6900
	18	70180041	1	DISTANZIALE INTERNO	INTERNAL SPACER	ENTRETOISE INTÉRIEUR	INTERNER ABSTANDHALTER	DISTANCIADOR INTERNO
	19	F000P02232	1	PIASTRINO GUIDA CAVO	CABLE GUIDE PLATE	PLAQUE GUIDE-CABLE	KABELFAHRUNG	PLACA GUIA CABLE
	20	YN0082751	1	VITE TCEIF M10x40	SCREW TCEIF M10x40	VIS TCEIF M10x40	SCHRAUBE TCEIF M10x40	TORNILLO TCEIF M10x40
	21	60ND07330	2	VITE TCEI M5x16	SCREW TCEI M5x16	VIS TCEI M5x16	SCHRAUBE TCEI M5x16	TORNILLO TCEI M5x16
	22	31120016	1	INTERRUTTORE CAVALLETTO	POWEROFF SWITCH	INTERRUPTEUR	SCHALTER	INTERRUPTOR
	23	F000P02470	1	MOLLA	SPRING	RESSORT	FEDER	MUELLE
	24	ZH0067545	1	VITE M6x12	SCREW M6x12	VIS M6x12	SCHRAUBE M6x12	TORNILLO M6x12
	25	72030710	1	VITE ROTAZIONE CAVALLETTO LATERALE	SIDE STAND SCREW	VIS BÉQUILLE	SCHRAUBE STÄNDER	TORNILLO CABALLETE
	26	F000P03493	1	CAVALLETTO LATERALE	LATERAL STAND	BÉQUILLE	STÄNDER	CABALLETE LATERAL
	27	FC00P01286	1	DISTANZIALE	SPACER	ENTRETOISE	ABSTANDHALTER	DISTANCIADOR
	28	F000P02851	1	CLIP	CLAMP	COLLIER	SHELLE	ABRAZADERA
	29	800056444	3	FASCETTA L=188 mm	CLAMP L=188 mm	COLLIER L=188 mm	SHELLE L=188 mm	ABRAZADERA L=188 mm
	30	ZT0069138	1	VITE TEF M10x70	SCREW M10x70	BOULON DE BRIDE M10x70	FLANSCHENSCHRAUBE M10x70	TORNILLO DE REBORDE M10x70
	31	Z00042022	5	DADO FLANGIATO M10	FLANGED NUT M10	ECROU BRIDE M10	FLANSCHMUTTER M10	TUERCA CON BRIDA M10
	32	F000P03458	1	PIASTRA ANT. DESTRA MOTORE	R.H. FRONT ENGINE PLATE	PLAQUE MOTEUR AV. DROIT	PLATTE MOTOR VORNE RECHTS	PLACA MOTOR DEL. DER.
	33	F000P03459	1	PIASTRA ANT. SINISTRA MOTORE	L.H. FRONT ENGINE PLATE	PLAQUE MOTEUR AV. GAUCHE	PLATTE MOTOR VORNE LINKE	PLACA MOTOR DEL. IZQ.

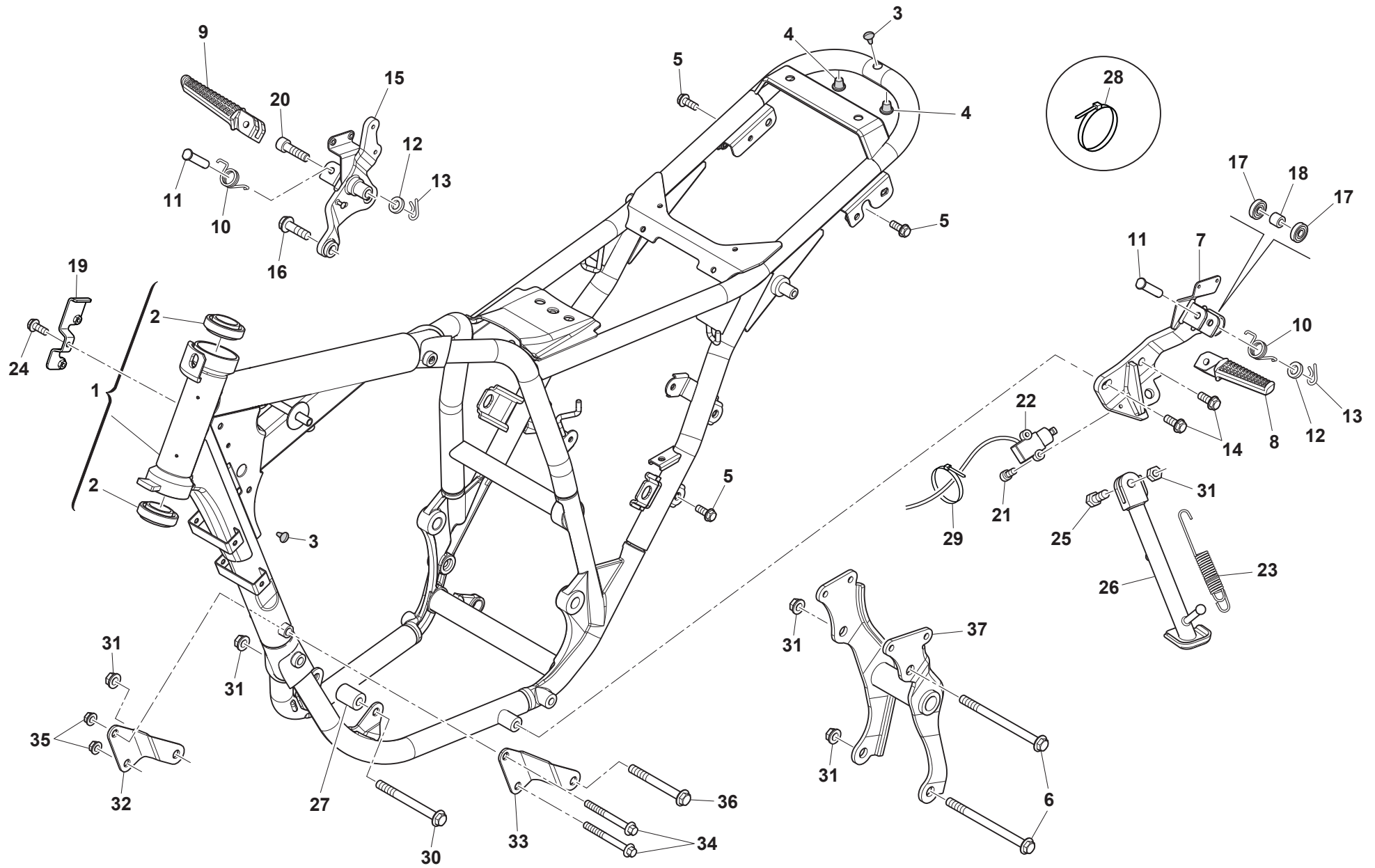

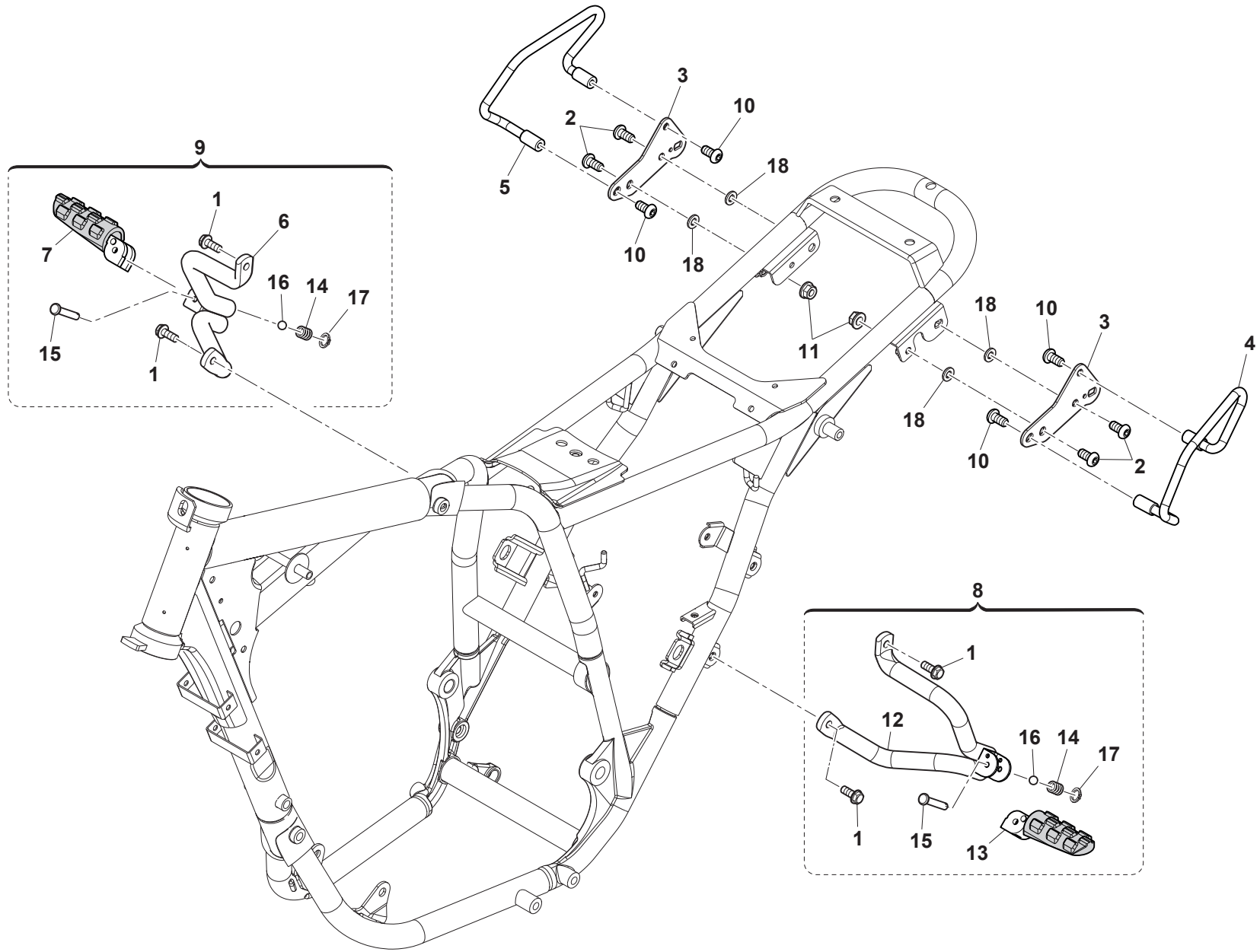



ACE OF SPADES 125 OUTLAW 125

PEDANE E MANIGLIE PASSEGGERO - PASSENGER FOOT RESTS AND HANDLES REPOSE PIEDS ET POIGNÉE PASSAGER - BEIFAHRERFUßRASTE UND GRIFF REPOSAPIES Y MANILLA ACOMPAÑANTE

TAVOLA
DRAWING
TABLE
BILD
TABLA

20A

Note Notes Notes Marke Notas	Pos. No. Index Pos.	N. Cod. Code No. Nr. Code Code Nr N. Cod.	Q.tà Q.ty Q.te M.ge C.ad	DENOMINAZIONE	NAME	DESIGNATION	BESHREIBUNG	DENOMINACION
	1	Z00069056	4	VITE TEF M8x20	FLANGED EXAGON HEAD SCREW M8x20	BOULON DE BRIDE M8x20	FLANSCHENSCHRAUBE M8x20	TORNILLO DE REBORDE M8x20
	2	YD0092876	2	VITE TEF M8x20	FLANGED EXAGON HEAD SCREW M8x20	BOULON DE BRIDE M8x20	FLANSCHENSCHRAUBE M8x20	TORNILLO DE REBORDE M8x20
	3	F000P02470	2	PIASTRINA	PLATE	PLAQUETTE	PLÄTTCHEN	PLACA
	4	80A0H1853	1	MANIGLIA SINISTRA	LEFT HANDLE	POIGNÉE GAUCHE	GRIFF LINKS	MANILLA IZQUIERDA
	5	80A0H1852	1	MANIGLIA DESTRA	RIGHT HANDLE	POIGNÉE DROITE	GRIFF RECHTS	MANILLA DERECHA
	6	F000P02173	1	SUPPORTO PEDANA DESTRA	R.H. FOOTREST SUPPORT	SUPPORT REPOSE-PIEDS DROITE	HALTERUNG FUßRASTE RECHTS	SOPORTE ESTRIBO DERECHA
	7	8A0085928	1	PEDANA PASSEGGERO DESTRA	PASSENGER R.H. FOOTREST	REPOSE-PIEDS DROIT	FUßRASTE RECHTS	ESTRIBO DERECHA
	8	F000A02170	1	ASS. PEDANA PASSEGGERO SINISTRA	PASSENGER L.H. FOOTREST ASSY	REPOSE-PIEDS GAUCHE COMPL.	ZSB. FUßRASTE LINKS	CONJ. ESTRIBO IZQUIERDA
	9	F000A02171	1	ASS. PEDANA PASSEGGERO DESTRA	PASSENGER R.H. FOOTREST ASSY	REPOSE-PIEDS DROIT COMPL.	ZSB. FUßRASTE RECHTS	CONJ. ESTRIBO DERECHA
	10	YA0092876	4	VITE M8x16	BOLT M8x16	VIS M8x16	SCHRAUBE M8x16	TORNILLO M8x16
	11	Y00043928	4	DADO FRENATO M8	SELF-LOCKING NUT M8	ECROU AUTOBLOQUANT M8	SELBSTSICHERNDE MUTTER M8	TUERCA AUTOBLOCANTE M8
	12	F000P02172	1	SUPPORTO PEDANA SINISTRA	L.H. FOOTREST SUPPORT	SUPPORT REPOSE-PIEDS GAUCHE	HALTERUNG FUßRASTE LINKS	SOPORTE ESTRIBO IZQUIERDA
	13	8A0085929	1	PEDANA PASSEGGERO SINISTRA	PASSENGER L.H. FOOTREST	REPOSE-PIEDS GAUCHE	FUßRASTE LINKS	ESTRIBO IZQUIERDA
	14	800062655	2	MOLLA	SPRING	RESSORT	FEDER	MUELLE
	15	ZB0053546	2	PERNO	PIN	AXE	BOLZEN	EJE
	16	6BN021507	2	SFERA	BALL	BILLE	KUGEL	BOLA
	17	66ND21308	2	ANELLO ELASTICO	CIRCLIP	CIRCLIP	SPRENGRING	ANILLO ELASTICO
	18	8000A6638	4	DISTANZIALE	SPACER	ENTRETOISE	ABSTANDHALTER	DISTANCIADOR

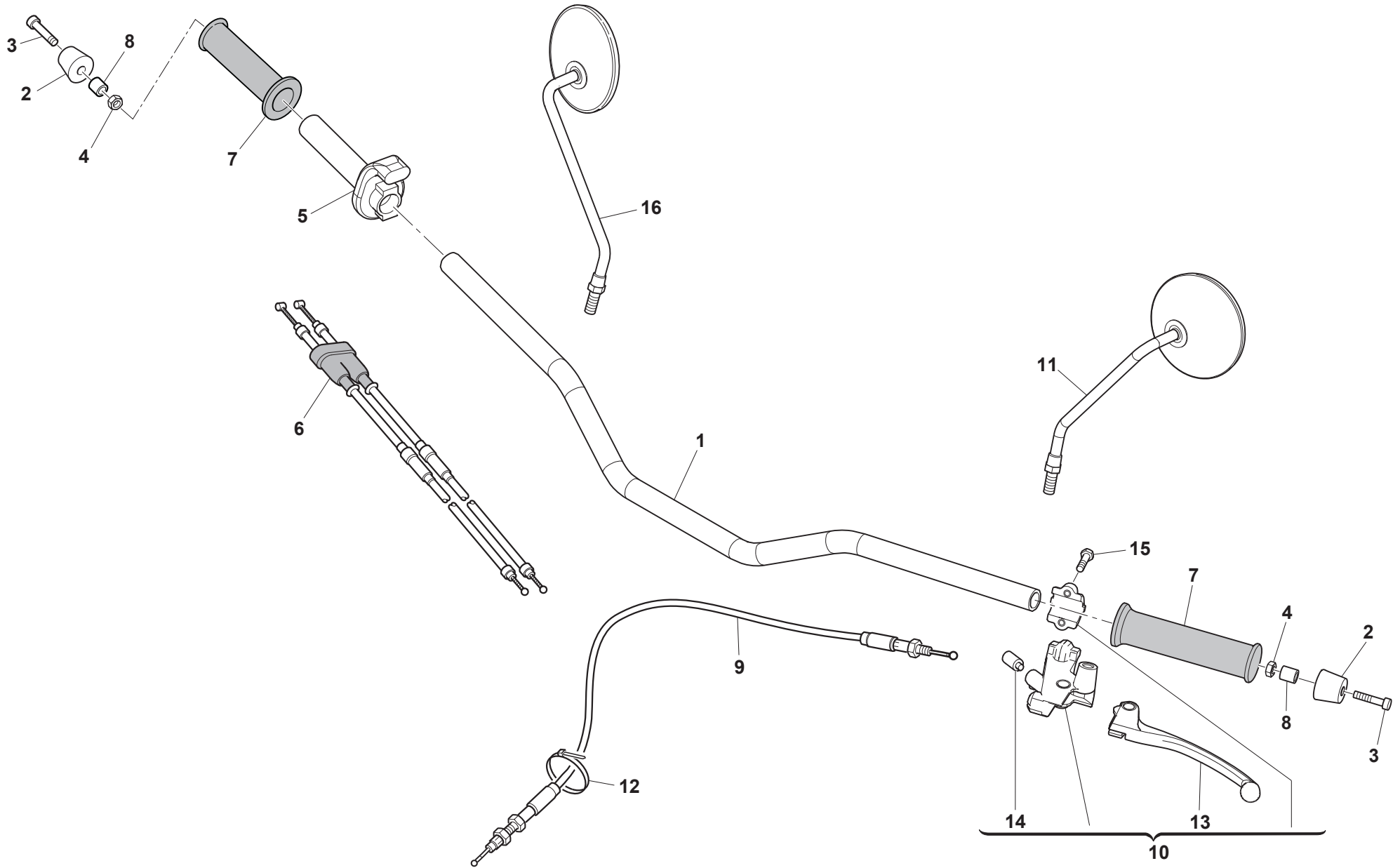



ACE OF SPADES 125 OUTLAW 125

MANUBRIO E COMANDI - HANDLEBAR AND CONTROLS GUIDON ET COMMANDES - LENKER UND STEUERORGANE MANILLAR Y MANDOS

TAVOLA
DRAWING
TABLE
BILD
TABLA

21

Note Notes Notes Marke Notas	Pos. No. N. Index Pos.	N. Cod. Code No. Nr. Code Code Nr N. Cod.	Q.tà Q.ty Q.te M.ge C.ad	DENOMINAZIONE	NAME	DESIGNATION	BESHREIBUNG	DENOMINACION
	1	F0A0P01543	1	MANUBRIO	HANDLEBAR	GUIDON	LENKER	MANILLAR
	2	F000P03133	2	CONTRAPPESO	COUNTERBALANCE	CONTREPOIDS	GEGENGEWICHT	CONTRAPESO
	3	60ND02519	2	VITE TEI M6x1	BOLT TEI M6x1	VIS TEI M6x1	SCHRAUBE TEI M6x1	TORNILLO TEI M6x1
	4	61ND15062	2	DADO M6x1	NUT M6x1	ECROU M6x1	MUTTER M6x1	TUERCA M6x1
	5	8000H6477	1	COMANDO GAS COMPLETO	COMPLETE THROTTLE CONTROL	COMMANDE DES GAZ COMPLÈTE	GASZUG KOMPLETT	MANDO ACELERADOR COMPLETO
	6	8000H2115	1	CAVO ACCELERATORE	CABLE ASSY, THROTTLE	CÂBLE COMMANDE DES GAZ	KABEL GASZUG	CABLE ACELERADOR
	7	F000A03134	1	MANOPOLE	HANDGRIPS	POIGNÉES	GRIFFE	PUÑOS
	8	F000P03586	2	TUBETTO	TUBE SPACER	TUYAU	ROHR	TUBO
	9	F000P03719	1	CAVO COMANDO FRIZIONE	CLUTCH CABLE	CÂBLE	KABEL	CABLE
	10	F000A03853	1	ASSIEME COMANDO FRIZIONE	CLUTCH CONTROL ASSY	COMMANDE EMBRAYAGE COMPL.	ZUSAMMENBAU KUPPLUNGSZUG	CONJUNTO MANDO EMBRAGUE
	11	FA00P02286	1	SPECCHIETTO RETROV. SX	L.H. REAR-VIEW MIRROR	RÉTROVISEUR GAUCHE	RÜCKSPIEGEL LINKE	ESPEJO RETROV. IZQ.
	12	800056444	2	FASCETTA	CLAMP	COLLIER	SHELLE	ABRAZADERA
	13	F000P03856	1	LEVA FRIZIONE	CLUTCH LEVER	LEVIER EMBRAYAGE	KUPPLUNGHEBEL	PALANCA EMBRAGUE
	14	45530027	1	INTERRUTTORE LEVA FRIZIONE	CLUTCH LEVER SWITCH	INTER. LEVIER EMBRAYAGE	KUPPLUNGSCHALTER	INTER.PALANCAEMBRAGUE
	15	Z00062728	2	VITE TEF M6x20	FLANGED EXAGON HEAD SCREW M6x20	BOULON DE BRIDE M6x20	SCHRAUBE M6x20	TORNILLO M6x20
	16	F000P02286	1	SPECCHIETTO RETROV. DX	R.H. REAR-VIEW MIRROR	RÉTROVISEUR DROITE	RÜCKSPIEGEL RECHTS	ESPEJO RETROV. DER.

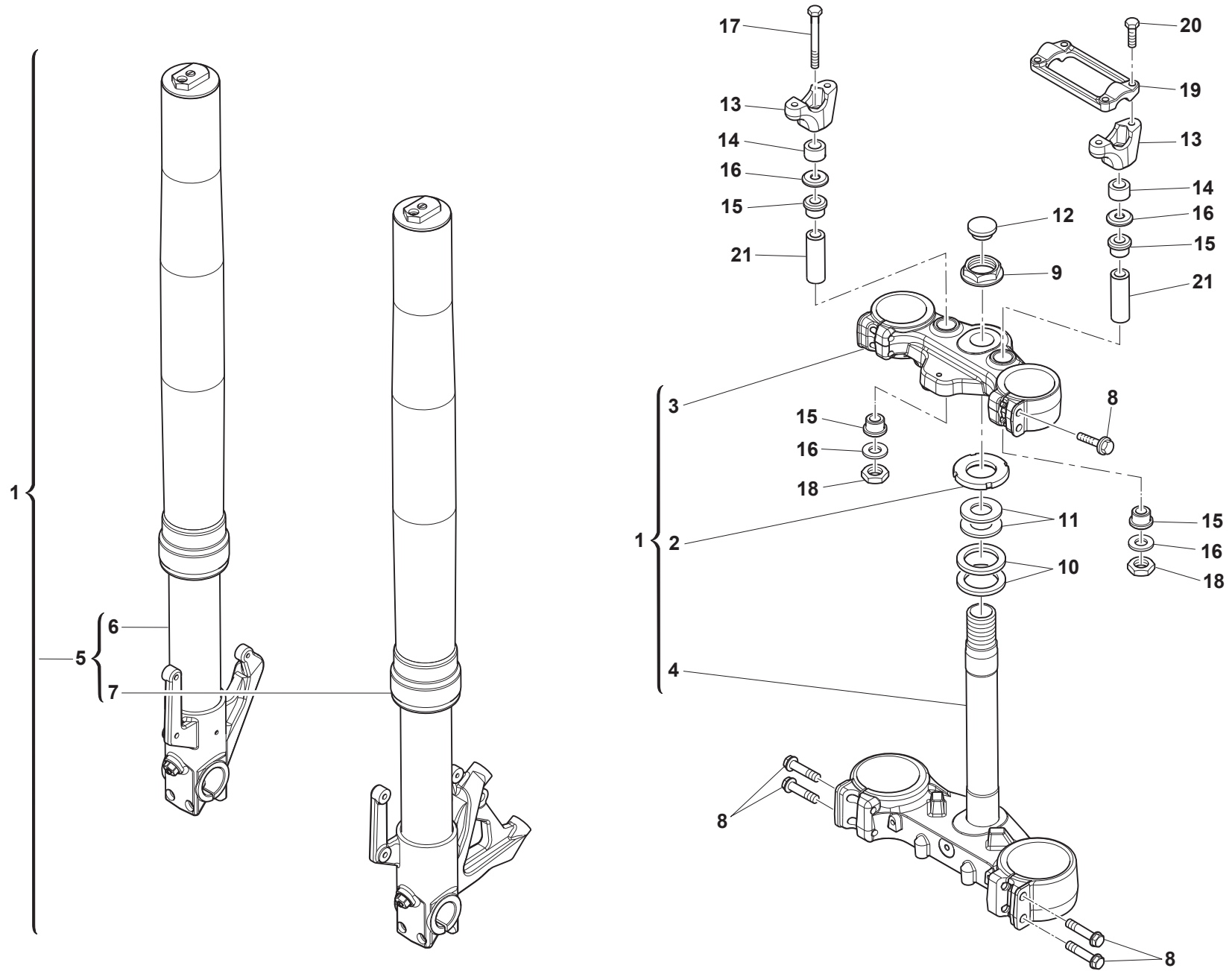



Note Notes Notes Marke Notas	Pos. No. Index Pos.	N. Cod. Code No. Nr. Code Code Nr N. Cod.	Q.tà Q.ty Q.te M.ge C.ad	DENOMINAZIONE	NAME	DESIGNATION	BESHREIBUNG	DENOMINACION
	1	F000A03494	1	ASS. SOSPENSIONE ANTERIORE	FRONT SUSPENSION ASSY	SUSPENSION AVANT	RADAUFHAENGUNG VORDER	SUSPENSION DELANTERA
	2	8A0087717	1	GHIERA PER PERNO DI STERZO	RING NUT	BAGUE	GEWINDERING	TUERCA ANULAR
	3	F000P03495	1	TESTA DI STERZO	STEERING HEAD	TETE DE DIRECTION	LENKKOPF	CABEZAL DE DIRECCIÓN
	4	F000A03496	1	BASE DI STERZO CON PERNO	BOTTOM YOKE WITH PIN	BASE DE DIRECTION AVEC AXE	LENKLAGER MIT BOLZEN	BASE DE DIRECCIÓN CON EJE
	5	F000A03498	1	ASSIEME GAMBE FORCELLA	FORK LEGS ASSY	ENSEMBLE FOURCHE	GABELGRUPPE	GRUPO HORQUILLA
	6	F000A03632	1	GAMBA DESTRA COMPLETA	COMPLETE R.H. SHOCK ABSORBER	BRANCHE DROITE COMPLÈTE	FEDERBEIN RECHTS KOMPLETT	PATA DER. COMPLETA
	7	F000A03633	1	GAMBA SINISTRA COMPLETA	COMPLETE L.H. SHOCK ABSORBER	BRANCHE GAUCHE COMPLÈTE	FEDERBEIN LINKE KOMPLETT	PATA IZQ. COMPLETA
	8	Z00062796	8	VITE TEF M8x40	FLANGED EXAGON HEAD SCREW M8x40	BOULON DE BRIDE M8x40	FLANSCHENSCHRAUBE M8x40	TORNILLO DE REBORDE M8x40
	9	8A0069315	1	DADO M26	NUT M26	ECROU M26	MUTTER M26	TUERCA M26
	10	800087736	2	ROSETTA	WASHER	RONDELLE	UNTERLEGSSCHEIBE	ARANDELA
	11	800087745	2	GUARNIZIONE	GASKET	JOINT	DICHTUNG	JUNTA
	12	F000P00912	1	TAPPO	PLUG	BOUCHON	STOPFEN	TAPON
	13	80A0H2355	2	MORSETTO INFERIORE MANUBRIO	LOWER CLAMP	ETRIER INFERIEUR	KLEMME UNTEN	BORNE INFERIOR
	14	8A00A6683	2	DISTANZIALE	SPACER	ENTRETOISE	ABSTANDHALTER	DISTANCIADOR
	15	800060233	4	SILENTBLOCK	SILENTBLOCK	SILENTBLOCK	SILENTBLOCK	SILENTBLOCK
	16	800060234	4	ROSETTA	WASHER	RONDELLE	UNTERLEGSSCHEIBE	ARANDELA
	17	60ND01222	2	VITE TE M10x80	FLANGED EXAGON HEAD SCREW M10x80	BOULON DE BRIDE M10x80	FLANSCHENSCHRAUBE M10x80	TORNILLO DE REBORDE M10x80
	18	Z00061314	2	DADO AUTOBLOCCANTE M10x1,5	SELF-LOCKING NUT M10x1,5	ECROU AUTOBLOQUANT M10x1,5	SELBSTSICHERNDE MUTTER M10x1,5	TUERCA AUTOBLOCCANTE M10x1,5
	19	80A0B0522	1	MORSETTO SUPERIORE MANUBRIO	UPPER CLAMP	ETRIER SUPERIEUR	KLEMME OBEN	BORNE SUPERIOR
	20	ZC0069056	4	VITE TEF M8x1,25x30	FLANGED EXAGON HEAD SCREW M8x1,25x30	BOULON DE BRIDE M8x1,25x30	FLANSCHENSCHRAUBE M8x1,25x30	TORNILLO DE REBORDEM8x1,25x30

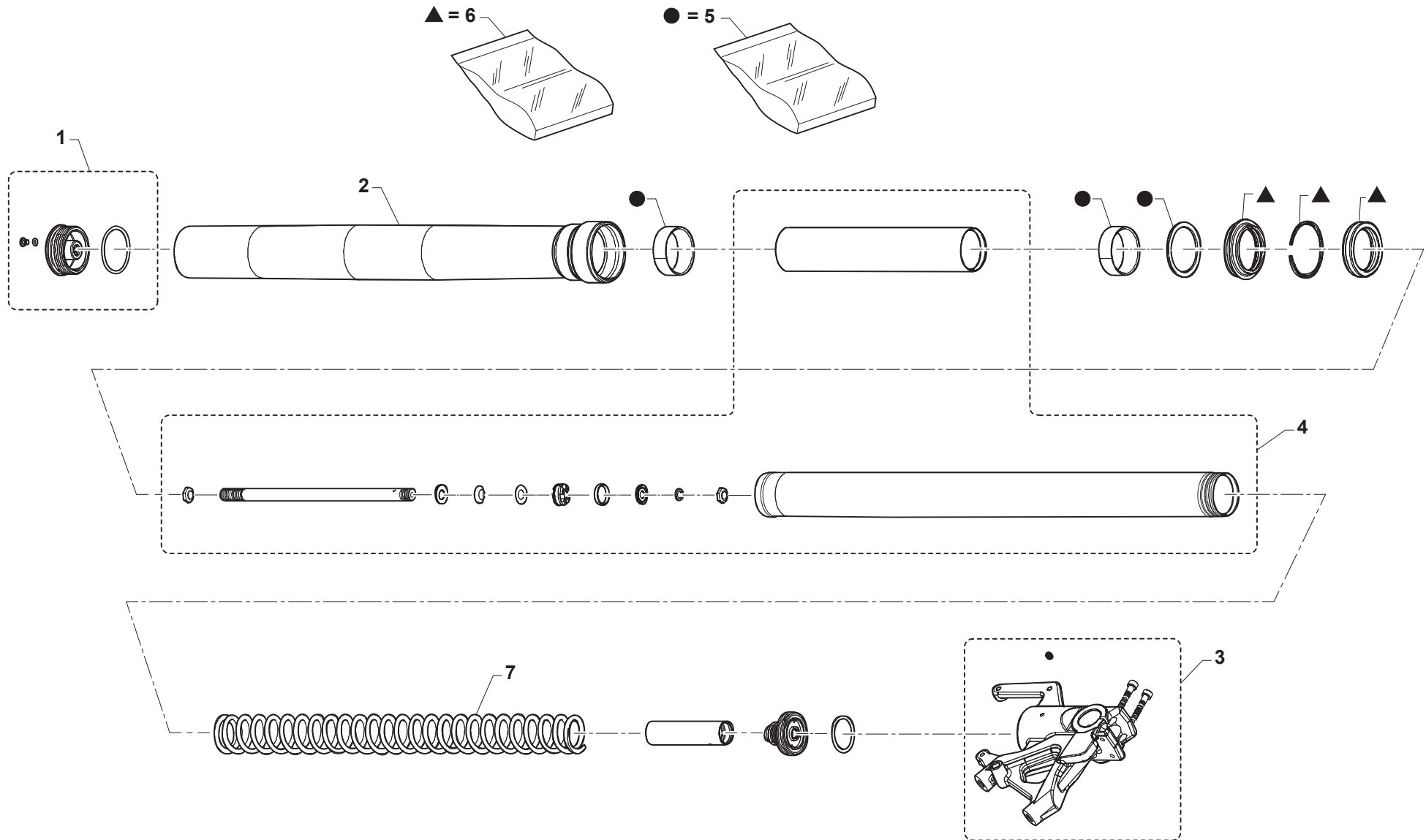



ACE OF SPADES 125 OUTLAW 125

FORCELLA SINISTRA - LEFT FORK FOURCHE GAUCHE - GABEL, LINKS HORQUILLA IZQUIERDA

TAVOLA
DRAWING
TABLE
BILD
TABLA

22A

Note Notes Marke Notas	Pos. No. Index Pos.	N. Cod. Code No. Nr. Code Code Nr N. Cod.	Q.tà Q.ty Q.te M.ge C.ad	DENOMINAZIONE	NAME	DESIGNATION	BESHREIBUNG	DENOMINACION
	1	F000P03634	1	GRUPPO TAPPO	PLUG ASSY	ENSEMBLE BOUCHON	STOPFENGRUPPE	GRUPO TAPON
	2	F000P03638	1	FODERO	SLEEVE	FOURREAU	GLEITROHRVERSCHLUSS	FUNDA
	3	F000P03637	1	GRUPPO FISSAGGIO RUOTA - SX	L.H. WHEEL FASTENING ASSY	GROUPE FIXATION ROUE - GAUCHE	GRUPPE BEFESTIGUNG - LINKS	GRUPO DE FIJACIÓN RUEDA - IZQ.
	4	F000P03639	1	STRUTTURA INTERNA SX	L.H. INNER STRUCTURE	STRUCTURE INTERNE GAUCHE	INTERNE STRUKTUR LINKS	COMPONENTES INTERNO IZQ.
	5	F000P03640	1	KIT BOCCOLE	BUSHING KIT	KIT DOUILLES	SATZ BUCHSEN	KIT CASQUILLOS
	6	F000P03641	1	KIT GUARNIZIONI	GASKET KIT	KIT JOINTS	SATZ DICHTUNGEN	KIT JUNTAS
	7	F000P03642	1	MOLLA	SPRING	RESSORT	FEDER	MUELLE

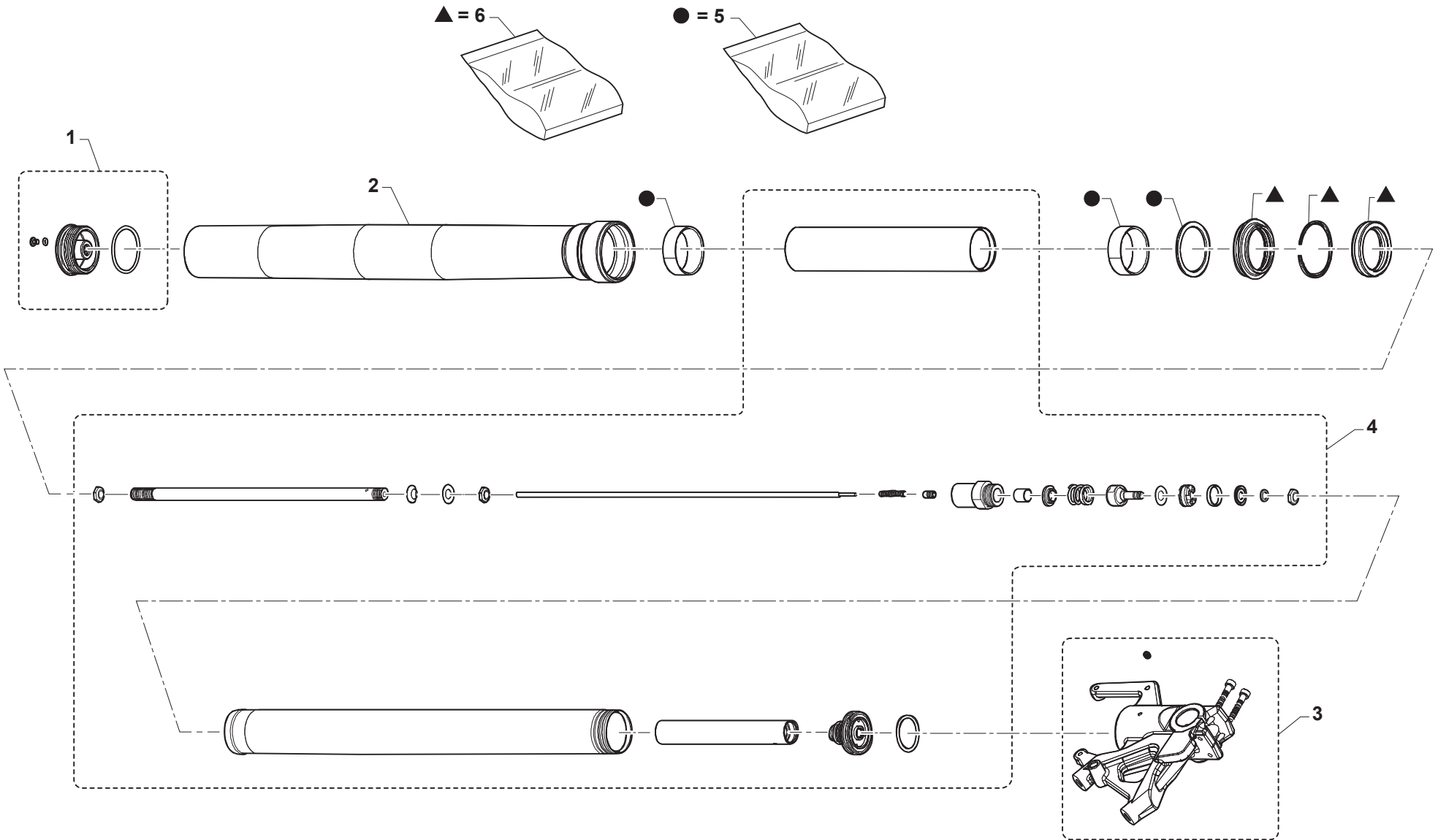

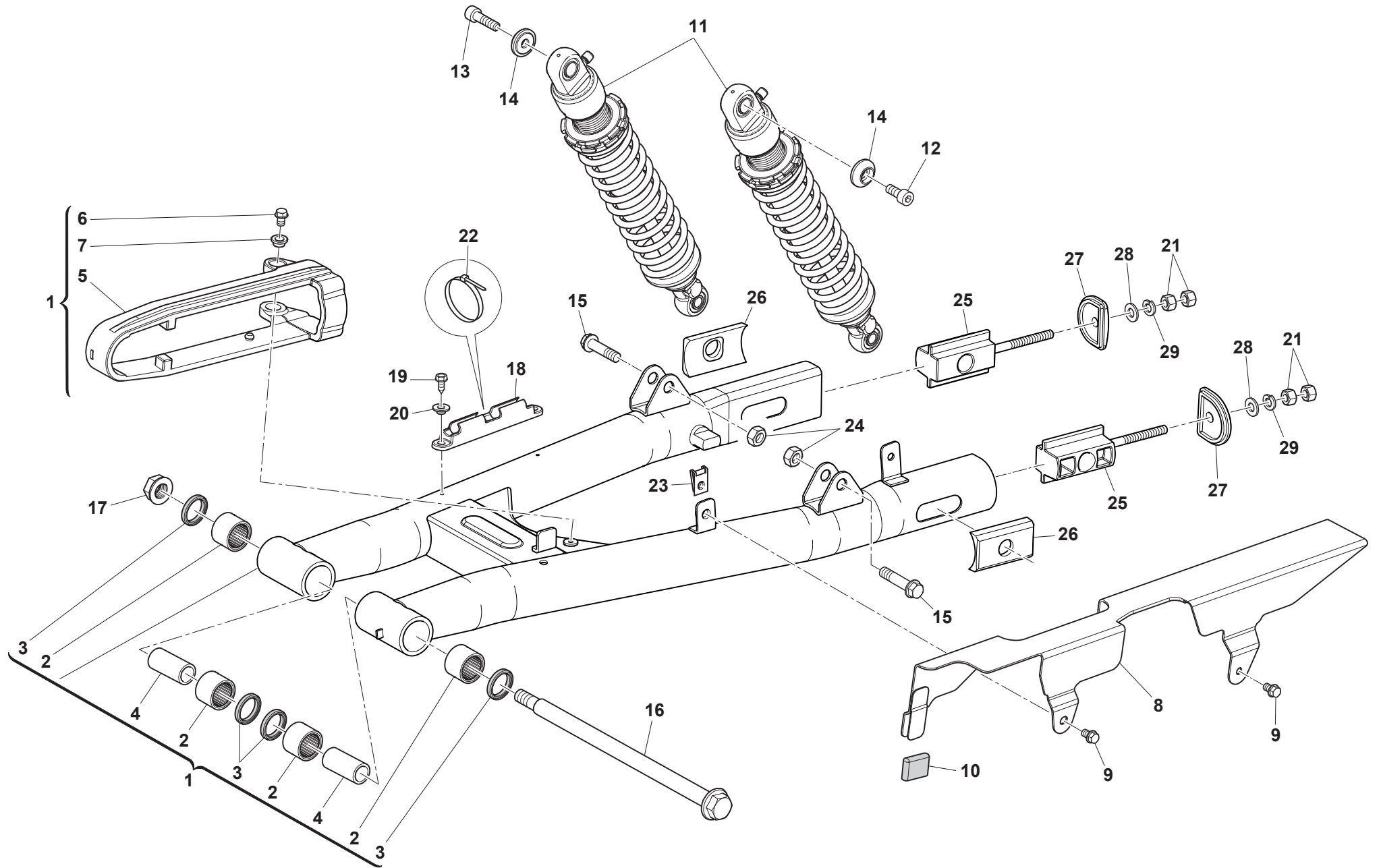



ACE OF SPADES 125 OUTLAW 125

FORCELLONE E AMMORTIZZATORE POSTERIORE - REAR SWING ARM AND SUSPENSION FOURCHE AT SUSPENSION ARRIERE - HINTERHAUFHANGUNG HORQUILLA Y SUSPENSION TRASERA

TAVOLA
DRAWING
TABLE
BILD
TABLA

23

Note Notes Notes Marke Notas	Pos. No. Index Pos.	N. Cod. Code No. Nr. Code Code Nr N. Cod.	Q.tà Q.ty Q.te M.ge C.ad	DENOMINAZIONE	NAME	DESIGNATION	BESHREIBUNG	DENOMINACION
	1	F000A02300	1	FORCELLONE COMPLETO	COMPLETE SWINGING ARM	BRAS OSCILLANT COMPLET	SCHWINGE KOMPLETT	BASCULANTE COMPLETO
	2	41280414	4	CUSCINETTO A RULLI 6903	BEARING 6903	ROULEMENT 6903	LAGER 6903	COJINETE 6903
	3	72110236	4	GUARNIZIONE FB 30x22x7	GASKET FB 30x22x7	JOINT FB 30x22x7	DICHTUNG FB 30x22x7	JUNTA FB 30x22x7
	4	70280011	2	BUSSOLA FORCELLONE	FORK BUSHING	DOUILLE BRAS OSCILLANT	BUCHSE SCHWINGE	CASQUILLO BASCULANTE
	5	F000P02380	1	PATTINO CATENA	CHAIN SLIDER	PATIN CHAÎNE	KETTENSANNERAUFLAGE	PATÍN CADENA
	6	72012225	2	VITE TC M6x12	SCREW TC M6x12	VIS TC M6x12	SCHRAUBE TC M6x12	TORNILLO TC M6x12
	7	70120280	2	BUSSOLA FLANGIATA	FLANGED BUSHING	DOUILLE À BRIDE	FLANSCHBUCHSE	CASQUILLO CON BRIDA
	8	F000P03648	1	COPRICATENA	CHAIN GUARD	CARTER DE CHAÎNE	KETTENKASTEN	CUBRECADENA
	9	Z00062725	2	VITE TEF M6x10	FLANGED EXAGON HEAD SCREW M6x10	BOULON DE BRIDE M6x10	FLANSCHENSCHRAUBE M6x10	TORNILLO DE REBORDE M6x10
	10	73012153	1	GOMMINO PER COPRICATENA	RUBBER FOR CHAIN COVER	JOINT EN CAOUTCHOUC	GUMMISCHEIBE	GOMA
	11	F000P01483	2	AMMORTIZZATORE POSTERIORE	REAR SHOCK ABSORBER	AMORTISSEUR ARRIÈRE COMPLET	STO&DÄMPFER KOMPLETT	AMORTIGUADOR COMPLETO
	12	60ND02555	1	VITE TCEI M8x20	SCREW TCEI M8x20	VIS TCEI M8x20	SCHRAUBE TCEI M8x20	TORNILLO TCEI M8x20
	13	60ND02557	1	VITE TCEI M8x30	SCREW TCEI M8x30	VIS TCEI M8x30	SCHRAUBE TCEI M8x30	TORNILLO TCEI M8x30
	14	F000P00760	2	RONDELLA CONICA	CONIC SPACER	RONDELLE CONIQUE	UNTERLEGSSCHEIBE	ARANDELA CONICA
	15	Z00062573	2	VITE TEF M10x40	FLANGED EXAGON HEAD SCREW M10x40	BOULON DE BRIDE M10x40	FLANSCHENSCHRAUBE M10x40	TORNILLO DE REBORDE M10x40
	16	70030169	1	PERNO FORCELLONE	SWINGING ARM PIN	AXE BRAS OSCILLANT	BOLZEN SCHWINGE	EJE BASCULANTE
	17	72020488	1	DADO M14x1,5	NUT M14x1,5	ECROU M14x1,5	MUTTER M14x1,5	TUERCA M14x1,5
	18	8000B1166	1	PASSATUBO	HOSE RING	PASSE-TUBE	LEITUNGSDURCHFÜHRUNG	PASATUBO
	19	Z00067997	2	VITE TEF M5x12	FLANGED EXAGON HEAD SCREW M5x12	BOULON DE BRIDE M5x12	FLANSCHENSCHRAUBE M5x12	TORNILLO DE REBORDE M5x12
	20	800069282	2	BUSSOLA D14-D7-D5,25	BUSHING D14-D7-D5,25	DOUILLE D14-D7-D5,25	BUCHSE D14-D7-D5,25	CASQUILLO D14-D7-D5,25
	21	61ND15035	4	DADO M8x1,25	NUT M8x1,25	ECROU M8x1,25	MUTTER M8x1,25	TUERCA M8x1,25
	22	800056783	2	FASCETTA	CLAMP	COLLIER	SHELLE	ABRAZADERA
	23	U00046893	2	DADO A GRAFFETTA M6	CLIP NUT M6	ECROU À AGRAFE M6	SICHERUNGSMUTTER M6	TUERCA DE CLIP M6
	24	Z00042022	2	DADO FLANGIATO M10x1,25	FLANGED NUT M10x1,25	ECROU BRIDE M10x1,25	FLANSCHMUTTER M10x1,25	TUERCA CON BRIDA M10x1,25
	25	F000P02216	2	TENDICATENA	CHAIN TENSIONER	TENDEUR DE CHAÎNE	KETTENSANNER	SENSOR DE CADENA
	26	F000P02217	2	PIASTRINA	PLATE	PLAQUETTE	PLÄTTCHEN	PLACA
	27	F000P02218	2	TERMINALE TUBO	END PIPE	BOUCHON	STOPFEN	TAPON
	28	62ND15506	2	ROSETTA	WASHER	RONDELLE	UNTERLEGSSCHEIBE	ARANDELA
	29	62ND15538	2	ROSETTA ELASTICA	SPRING WASHER	RONDELLE ELASTIQUE	SPRENGSCHEIBE	ARANDELA ELASTICA

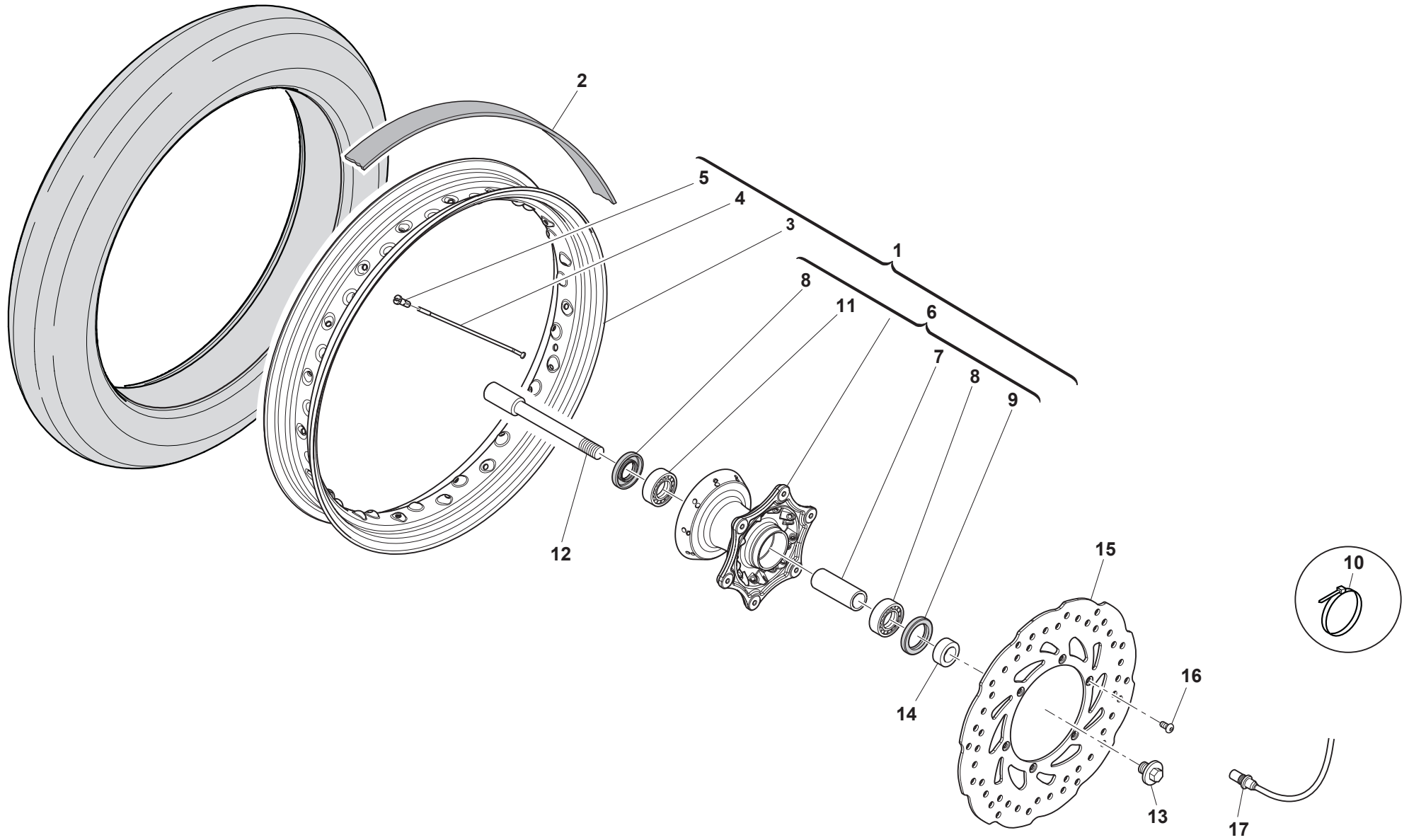



ACE OF SPADES 125 OUTLAW 125

RUOTA ANTERIORE - FRONT WHEEL ROUE AVANT - VORTERRAD RUEDA DELANTERA

TAVOLA
DRAWING
TABLE
BILD
TABLA

24

Note Notes Notes Marke Notas	Pos. No. Index Pos.	N. Cod. Code No. Nr. Code Code Nr N. Cod.	Q.tà Q.ty Q.te M.ge C.ad	DENOMINAZIONE	NAME	DESIGNATION	BESHREIBUNG	DENOMINACION
	1	F000A03627	1	RUOTA ANTERIORE SENZA PNEUMATICO	FRONT WHEEL WITHOUT TYRE	ROUE AVANT SANS PNEU	VORDERRAD OHNE TYRE	RUEDA DELANTERA SIN NEUMÁTICO
	2	54090026	1	PROTEZIONE CAMERA D'ARIA	AIR TUBE PROTECTION	VAINE DE PROTECTION	HULLE	VAINA DE PROTECCION
	3	F000P03867	1	CERCHIO RUOTA ANT. 3,50"x17"	FRONT WHEEL RIM 3,50"x17"	JANTE ROUE AVANT 3,50"x17"	FELGE VORDERRAD 3,50"x17"	LLANTA RUEDA DEL. 3,50"x17"
	4	F000P03868	18	RAGGIO 3,5x170	SPOKE 3,5x170	BRAS 3,5x170	SPEICHE 3,5x170	RADIO 3,5x170
	4	F000P03869	18	RAGGIO 3,5x168	SPOKE 3,5x168	BRAS 3,5x168	SPEICHE 3,5x168	RADIO 3,5x168
	5	F000P03870	36	NIPPLO	NIPPLE	NIPPLE	NIPPEL	NIPLE
	6	F000A03871	1	MOZZO RUOTA ANTERIORE	FRONT WHEEL HUB	MOYEU	NABE	CUBO
	7	F000P03875	1	DISTANZIALE INTERNO	INTERNAL SPACER	ENTRETOISE INTÉRIEUR	INTERNER ABSTANDHALTER	DISTANCIADOR INTERNO
	8	F000P03873	2	CUSCINETTO A SFERE	BALL BEARING	ROULEMENT À BILLES	KUGELLAGER	COJINETE DE BOLAS
	9	F000P02036	1	ANELLO 25x47x7	SEAL RING 25x47x7	BAGUE 25x47x7	RING 25x47x7	ANILLO 25x47x7
	10	800092668	3	FASCETTA	CLAMP	COLLIER	SHELLE	ABRAZADERA
	11	F000P03874	1	ANELLO DI TENUTA 32x47x7	SEALING RING 32x47x7	BAGUE D'ETANCHEITE 32x47x7	DICHTUNGSRING 32x47x7	ANILLO DE ESTANQUEIDAD 32x47x7
	12	F000P01323	1	PERNO RUOTA	WHEEL AXLE	PIVOT DE ROUE	RADASCHE	EJE RUEDA
	13	F000P01324	1	TAPPO	PLUG	BOUCHON	STOPFEN	TAPON
	14	F000P01322	1	DISTANZIALE	SPACER	ENTRETOISE	ABSTANDHALTER	DISTANCIADOR
	15	F000P03415	1	DISCO FRENO ANTERIORE	FRONT BRAKE DISC	DISQUE DE FREIN	BREMSSCHEIBE	DISCO FRENO
	16	ZB0061070	4	VITE M6x16	SCREW M6x16	VIS M6x16	SCHRAUBE M6x16	TORNILLO M6x16
	17	E000P03631	1	SENSORE VELOCITA	SPEED SENSOR	CAPTEUR DE VITESSE	GESCHWINDIGKEITSSENSOR	SENSOR VELOCIDAD
	10	800092668	3	FASCETTA	CLAMP	COLLIER	SHELLE	ABRAZADERA

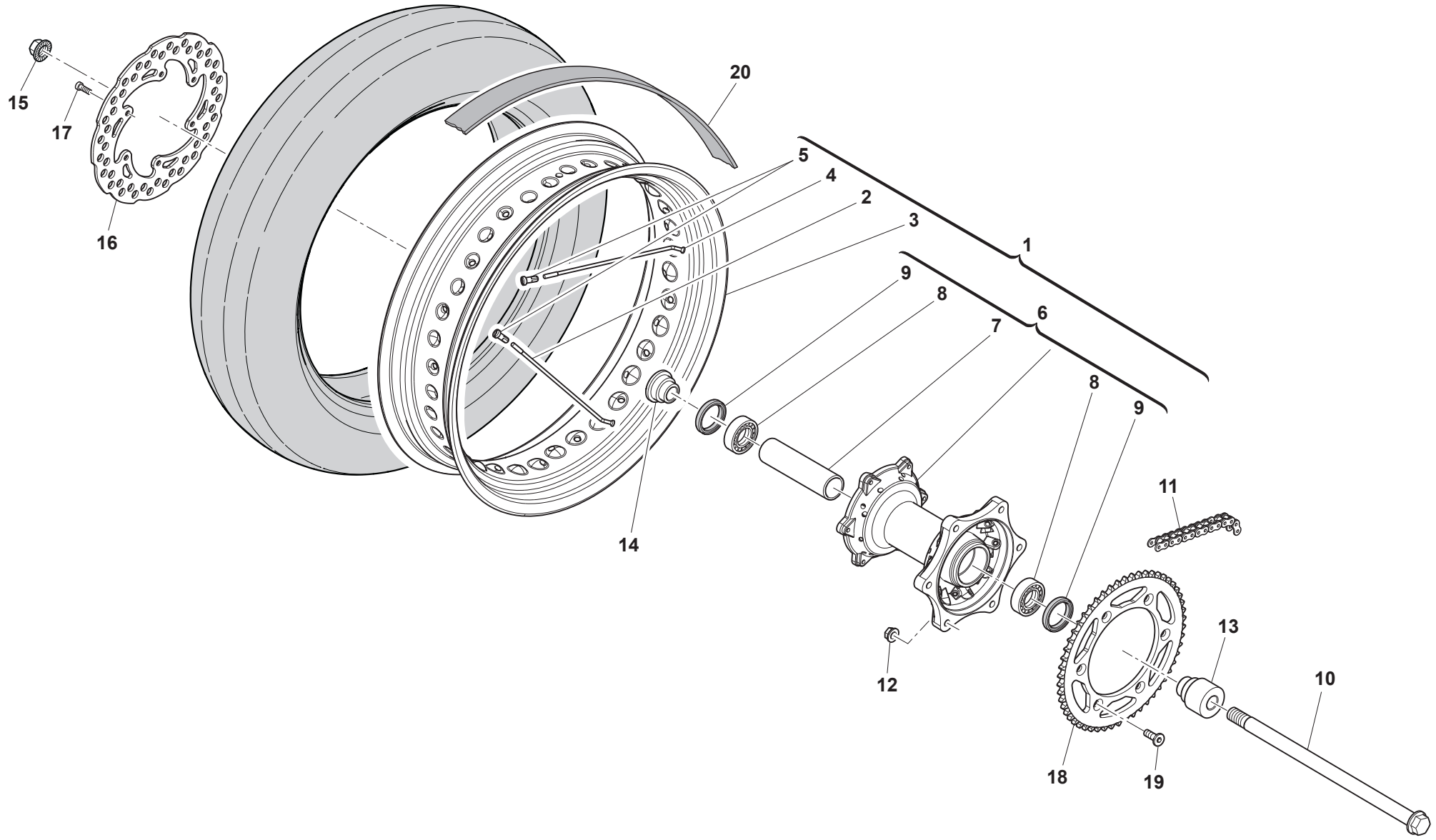



ACE OF SPADES 125 OUTLAW 125

RUOTA POSTERIORE - REAR WHEEL ROUE ARRIERE - HINTERRAD RUEDA TRASERA

TAVOLA
DRAWING
TABLE
BILD
TABLA

25

Note Notes Marke Notas	Pos. N. Index Pos.	N. Cod. Code No. Nr. Code Code Nr N. Cod.	Q.tà Q.ty Q.te M.ge C.ad	DENOMINAZIONE	NAME	DESIGNATION	BESHREIBUNG	DENOMINACION
	1	F000A03628	1	RUOTA POSTERIORE SENZA PNEUMATICO	REAR WHEEL WITHOUT TYRE	ROUE ARRIÈRE SANS PNEU	HINTERRAD OHNE TYRE	RUEDA TRASERA SIN NEUMÁTICO
	2	F000P03878	18	RAGGIO 4.0x184	SPOKE 4.0x184	BRAS 4.0x184	SPEICHE 4.0x184	RADIO 4.0x184
	3	F000P03876	1	CERCHIO RUOTA POST. 4,25"x17"	REAR WHEEL RIM 4,25"x17"	JANTE ROUE ARRIÈRE 4,25"x17"	FELGE HINTERRAD 4,25"x17"	LLANTA RUEDA TRAS. 4,25"x17"
	4	F000P03877	18	RAGGIO 4.0x190	SPOKE 4.0x190	BRAS 4.0x190	SPEICHE 4.0x190	RADIO 4.0x190
	5	F000P03879	36	NIPPLO	NIPPLE	NIPPLE	NIPPEL	NIPLE
	6	F000A03880	1	ASSIEME MOZZO RUOTA POSTERIORE	REAR WHEEL HUB ASSY	MOYEU DE ROUE ARRIERE COMPLET	NABE HALTERUNG HINTEN KOMPLETT	CUBO RUEDA TRASERO COMPLETO
	7	F000P03883	1	DISTANZIALE 32x26x121.6	SPACER 32x26x121.6	ENTRETOISE 32x26x121.6	ABSTANDHALTER 32x26x121.6	DISTANCIADOR 32x26x121.6
	8	F000P03882	2	CUSCINETTO	BEARING	ROULEMENT	LAGER	COJINETE
	9	F000P02333	1	PERNO RUOTA POSTERIORE	REAR WHEEL AXLE	PIVOT DE ROUE	RADASCHE	EJE RUEDA
	10	F000P03874	2	PARAOLIO 32x47x7	OIL SEAL 32x47x7	JOINT PARE-HUILE 32x47x7	ÖLDICHTRING 32x47x7	RETÉN DE ACEITE 32x47x7
	11	F000P03523	1	CATENA	CHAIN	CHAÎNE	KETTE	CADENA
	12	Y00043928	6	DADO FLANGIATO M8	FLANGED NUT M8	ECROU BRIDE M8	FLANSCHMUTTER M8	TUERCA CON BRIDA M8
	13	F000P03519	1	DISTANZIALE SINISTRO	LEFT SPACER	ENTRETOISE GAUCHE	ABSTANDHALTER LINKS	DISTANCIADOR IZQUIERDO
	14	F000P03520	1	DISTANZIALE DESTRO	RIGHT SPACER	ENTRETOISE DROIT	ABSTANDHALTER RECHTS	DISTANCIADOR DERECHO
	15	72020489	1	DADO M16	NUT M16	ECROU M16	MUTTER M16	TUERCA M16
	16	F000P01330	1	DISCO FRENO POSTERIORE	REAR BRAKE DISC	DISQUE DE FREIN	BREMSSCHEIBE	DISCO FRENO
	17	ZB0061070	6	VITE TTEI M6x16	BOLT TTEI M6x16	VIS TTEI M6x16	SCHRAUBE TTEI M6x16	TORNILLO TTEI M6x16
	18	F000P03522	1	CORONA DENTATA Z=54	CHAIN SPROCKET T=54	COURONNE DENTÉE D=54	ZAHNKRANZ Z=54	CORONA DENTADA Z=54
	19	8000H0158	6	VITE SPECIALE TSEI M8x28	SPECIAL BOLT TSEI M8x28	VIS SPÉCIAUX TSEI M8x28	SPEZIALSCHRAUBE TSEI M8x28	TORNILLO ESPECIAL TSEI M8x28
	20	54090026	1	PROTEZIONE CAMERA D'ARIA	AIR TUBE PROTECTION	VAINE DE PROTECTION	HULLE	VAINA DE PROTECCION

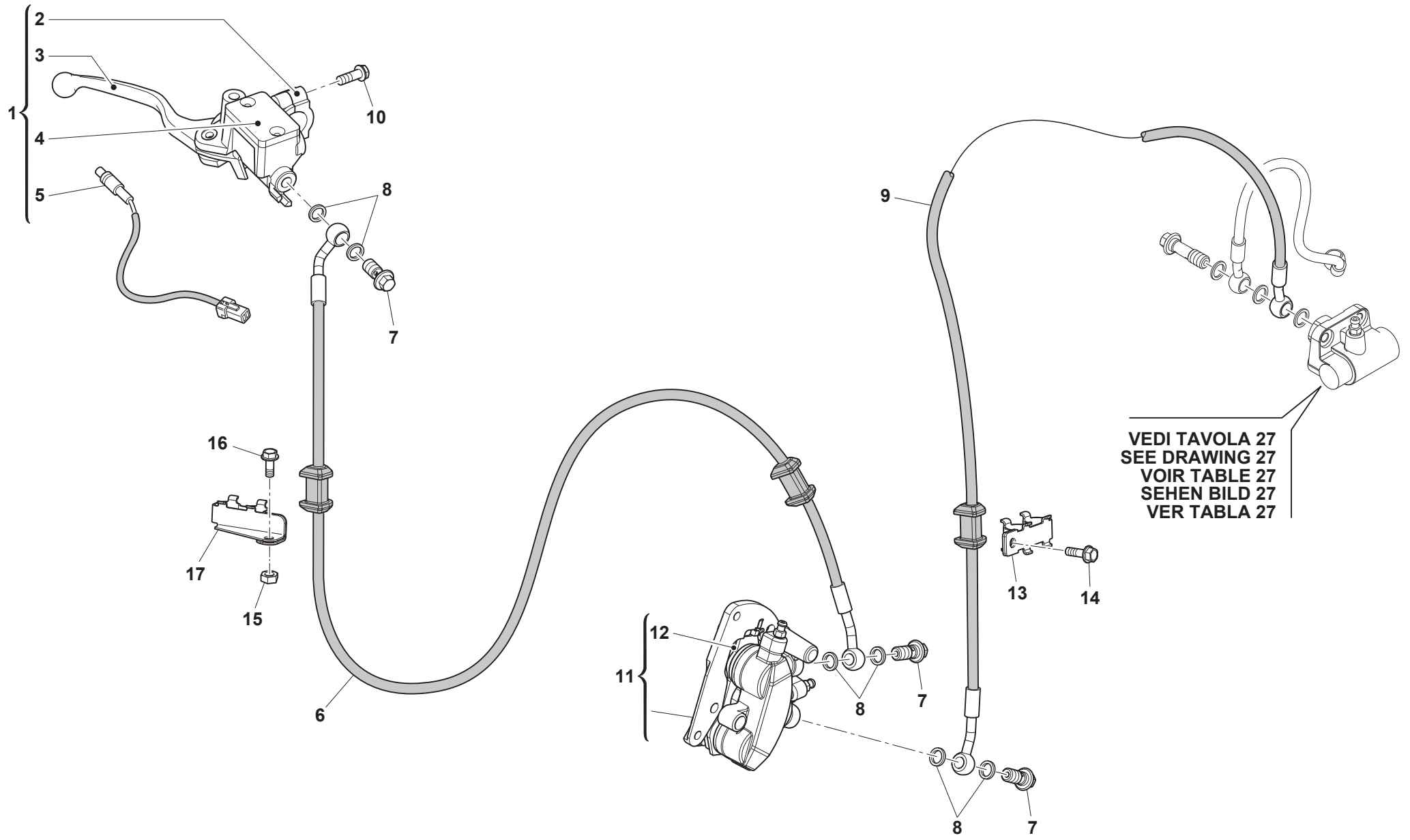



ACE OF SPADES 125 OUTLAW 125

FRENO IDRAULICO ANTERIORE - FRONT HYDRAULIC BRAKE FREIN HYDRAULIQUE AVANT - VORDERBREMSE FRENO HIDRAULICO DELANTERO

TAVOLA
DRAWING
TABLE
BILD
TABLA

26

Note Notes Marke Notas	Pos. No. Index Pos.	N. Cod. Code No. Nr. Code Code Nr N. Cod.	Q.tà Q.ty Q.te M.ge C.ad	DENOMINAZIONE	NAME	DESIGNATION	BESHREIBUNG	DENOMINACION
	1	F000A01289	1	COMANDO FRENO ANTERIORE	FRONT BRAKE CONTROL	COMMANDE FREIN	BREMSZUG	MANDO FRENO
	2	F000P01617	1	FISSAGGIO	CONNECT CLIP	FIXATION	BEFESTIGUNG	FIJACIÓN
	3	F000P01618	1	LEVA FRENO ANTERIORE	FRONT BRAKE LEVER	LEVIER	HEBEL	PALANCA
	4	F000P01619	1	TAPPO	PLUG	BOUCHON	STOPFEN	TAPON
	5	F000P01620	1	INTERRUTTORE POMPA FRENO	FRONT BRAKE PUMP SWITCH	INTERRUPTEUR DE FREIN	SCHALTER	INTERRUPTOR FRENO
	6	F000P03509	1	TUBO FRENO ANTERIORE	FRONT BRAKE HOSE	TUYAU DE FREIN AVANT	ROHR VORDERRADBREMSE	TUBO FRENO DELANTERO
	7	F000P02044	3	VITE TE M10x19	HEXAGON SOCKET-HEAD BOLT M10x19	VIS M10x19	SCHRAUBE M10x19	TORNILLO M10x19
	8	800021480	6	ROSETTA	WASHER	RONDELLE	UNTERLEGSCHNEIBE	ARANDELA
	9	F000P03511	1	TUBO PINZA FRENO - CBS	CBS - BRAKE CALLIPER PIPE	TUYAU ETRIER DE FREIN - CBS	ROHR BREMSSELTEL - CBS	TUBO PINZA FRENO - CBS
	10	Z00062727	2	VITE TEF M6x16	FLANGED EXAGON HEAD SCREW M6x16	BOULON DE BRIDE M6x16	FLANSCHENSCHRAUBE M6x16	TORNILLO DE REBORDE M6x16
	11	F000A01621	1	PINZA FRENO ANTERIORE	FRONT BRAKE CALLIPER	ETRIER DE FREIN AVANT	BREMSSELTEL VORDERR	PINZA FRENO DELANTERO
	12	F000P02030	1	COPPIA PASTIGLIE	PAIR OF BRAKE PADS	PAIRE PLAQUETTES	PAAR BREMSBELÄGE	PAREJA PASTILLAS
	13	F000P03799	1	PIASTRINA	PLATE	PLAQUETTE	PLÄTTCHEN	PLACA
	14	Z00062726	1	VITE TEF M6x14	FLANGED EXAGON HEAD SCREW M6x14	BOULON DE BRIDE M6x14	FLANSCHENSCHRAUBE M6x14	TORNILLO DE REBORDE M6x14
	15	Z00061355	1	DADO AUTOBLOCCANTE M5	SELF-LOCKING NUT M5	ECROU AUTOBLOQUANT M5	SELBSTSICHERNDE MUTTER M5	TUERCA AUTOBLOCANTE M5
	16	Z00067997	1	VITE TEF M5x12	FLANGED EXAGON HEAD SCREW M5x12	BOULON DE BRIDE M5x12	FLANSCHENSCHRAUBE M5x12	TORNILLO DE REBORDE M5x12
	17	F000P03530	1	PIASTRINA	PLATE	PLAQUETTE	PLÄTTCHEN	PLACA

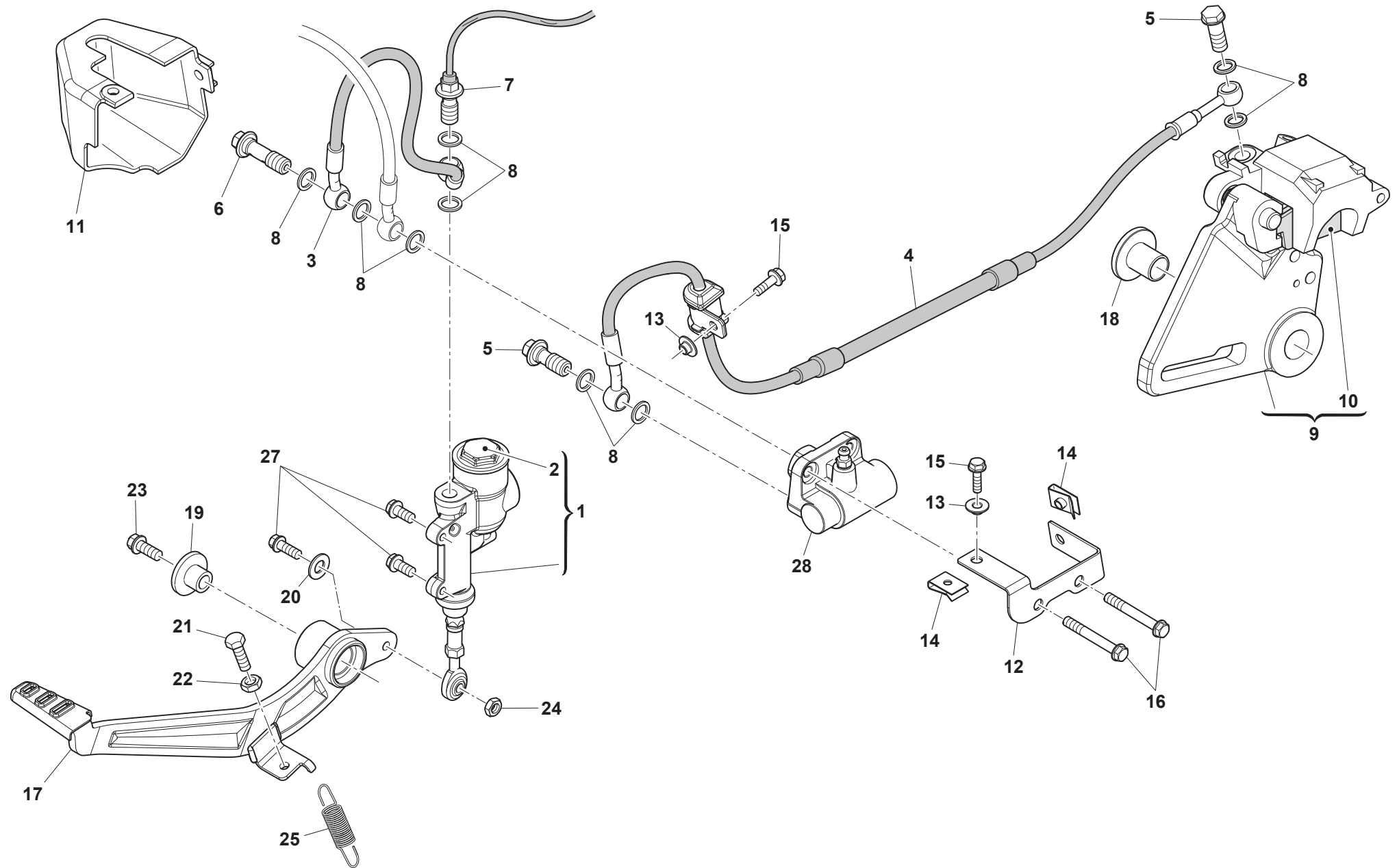



Note Notes Marke Notas	Pos. No. Index Pos.	N. Cod. Code No. Nr. Code Code Nr N. Cod.	Q.tà Q.ty Q.te M.ge C.ad	DENOMINAZIONE	NAME	DESIGNATION	BESHREIBUNG	DENOMINACION
	1	F000A01294	1	POMPA FRENO POSTERIORE	REAR BRAKE PUMP	MAÎTRE-CYLINDRE DE FREIN	ZUSAMMENBAU HAUPTBREMSZYLINDER	CONJUNTO BOMBA FRENO
	2	F000P02039	1	TAPPO SERBATOIO FRENO POSTERIORE	REAR BRAKE TANK CAP	BOUCHON RESERVOIR DE FREIN ARRIERE	TANKDECKEL HINTERRADBREMSE	TAPON DEPÓSITO FRENO TRASERO
	3	F000P03510	1	TUBO POMPA - CBS	CBS - PUMP PIPE	TUYAU POMPE - CBS	ROHR PUMPE - CBS	TUBO BOMBA - CBS
	4	F000P03512	1	TUBO PINZA FRENO - CBS	CBS - BRAKE CALLIPER PIPE	TUYAU ETRIER DE FREIN - CBS	ROHR BREMSSELLE - CBS	TUBO PINZA FRENO - CBS
	5	F000P02044	2	VITE TE M10x19	HEXAGON SOCKET-HEAD BOLT M10x19	VIS M10x19	SCHRAUBE M10x19	TORNILLO M10x19
	6	F000P02043	1	VITE TE M10x28	HEXAGON SOCKET-HEAD BOLT M10x28	VIS M10x28	SCHRAUBE M10x28	TORNILLO M10x28
	7	F000P02042	1	INTERRUTTORE STOP POSTERIORE	REAR STOP SWITCH	INTERRUPTEUR STOP ARRIÈRE	BREMSLICHTSCHALTER	INTERRUPTOR FRENO TRASERO
	8	800021480	9	ROSETTA	WASHER	RONDELLE	UNTERLEGSSCHEIBE	ARANDELA
	9	F000A03886	1	PINZA FRENO POSTERIORE	REAR BRAKE CALLIPER	ETRIER DE FREIN ARRIERE	BREMSSATTEL HINT.	PINZA FRENO TRASERO
	10	F000P02029	1	COPPIA PASTIGLIE	PAIR OF BRAKE PADS	PAIRE PLAQUETTES	PAAR BREMSBELÄGE	PAREJA PASTILLAS
	11	F000P01568	1	PROTEZIONE	PROTECTION	PROTECTION	SCHUTZ	PROTECCIÓN
	12	F000P01569	1	PIASTRINA	PLATE	PLAQUETTE	PLÄTTCHEN	PLACA
	13	800069282	2	BUSSOLA Ø14xØ5,25Ø4,8	BUSHING Ø14xØ5,25Ø4,8	DOUILLE Ø14xØ5,25Ø4,8	BUCHSE Ø14xØ5,25Ø4,8	CASQUILLO Ø14xØ5,25Ø4,8
	14	U00055134	2	DADO A GRAFFETTA	CLIP NUT	ECROU À AGRAFE	SICHERUNGSMUTTER	TUERCA DE CLIP
	15	ZA0067997	2	VITE TEF M5x16	FLANGED EXAGON HEAD SCREW M5x16	BOULON DE BRIDE M5x16	FLANSCHENSCHRAUBE M5x16	TORNILLO DE REBORDE M5x16
	16	Z00062731	2	VITE TEF M6x45	FLANGED EXAGON HEAD SCREW M6x45	BOULON DE BRIDE M6x45	FLANSCHENSCHRAUBE M6x45	TORNILLO DE REBORDE M6x45
	17	F000A00513	1	PEDALE COMANDO FRENO	BRAKE CONTROL PEDAL	PÉDALE COMMANDE DE FREIN	BREMSPEDAL	PEDAL MANDO FRENO
	18	F000P03521	1	DISTANZIALE	SPACER	ENTRETOISE	ABSTANDHALTER	DISTANCIADOR
	19	70230006	1	BUSSOLA FLANGIATA	FLANGED BUSHING	DOUILLE A BRIDE	FLANSCHBUCHSE	CASQUILLO CON BRIDA
	20	Z00045499	1	ROSETTA	WASHER	RONDELLE	UNTERLEGSSCHEIBE	ARANDELA
	21	60ND01081	1	VITE TE M6x25	HEXAGON SOCKET-HEAD BOLT M6x25	VIS M6x25	SCHRAUBE M6x25	TORNILLO M6x25
	22	61ND15033	1	DADO M6	NUT M6	ECROU M6	MUTTER M6	TUERCA M6
	23	Z00062727	1	VITE TEF M6x16	FLANGED EXAGON HEAD SCREW M6x16	BOULON DE BRIDE M6x16	FLANSCHENSCHRAUBE M6x16	TORNILLO DE REBORDE M6x16
	24	Z00061313	1	DADO M6	NUT M6	ECROU M6	MUTTER M6	TUERCA M6
	25	8000H5148	1	MOLLA PEDALE FRENO	RETURN SPRING	RESSORT	FEDER	MUELLE
	26	Z00062727	1	VITE TEF M6x16	FLANGED EXAGON HEAD SCREW M6x16	BOULON DE BRIDE M6x16	FLANSCHENSCHRAUBE M6x16	TORNILLO DE REBORDE M6x16
	27	Z00062726	2	VITE TEF M6x16	FLANGED EXAGON HEAD SCREW M6x16	BOULON DE BRIDE M6x16	FLANSCHENSCHRAUBE M6x16	TORNILLO DE REBORDE M6x16
	28	F000P01295	1	RIPARTITORE DI FRENATA CBS	DISTRIBUTION FRAME BRAKING	REPARTITEUR POUR LE FREINAGE	VERTEILER FÜR BREMSE	RED DE DISTRIBUCION PARA FRENADO

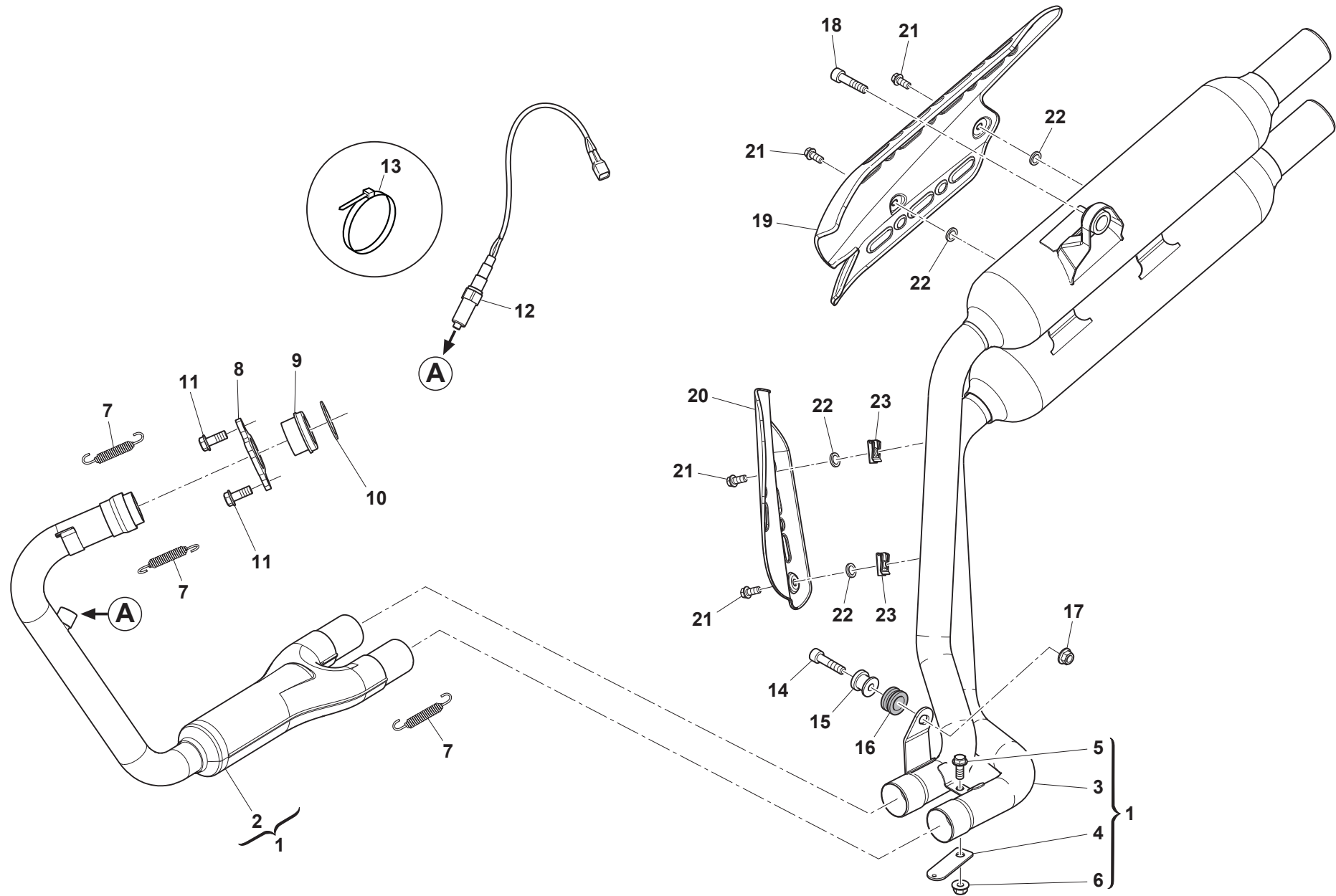



Note Notes Notes Marke Notas	Pos. No. N. Index Pos.	N. Cod. Code No. Nr. Code Code Nr N. Cod.	Q.tà Q.ty Q.te M.ge C.ad	DENOMINAZIONE	NAME	DESIGNATION	BESHREIBUNG	DENOMINACION
	1	F000A03508	1	ASS. IMPIANTO DI SCARICO	EXHAUST SYSTEM ASSY	INSTALLATION DE ECHAPPEMENT	AUSPUFFROHR KOMPLETT	EQUIPO DE ESCAPE
	2	F000P03404	1	TUBO DI SCARICO	EXHAUST PIPE	POT D'ÉCHAPPEMENT	AUSPUFFROHR	TUBO DE ESCAPE
	3	F000P03615	1	SILENZIATORE DI SCARICO	SILENCER	SILENCIEUX	SCHALLDÄMPFER	SILENCIADOR
	4	F000P03900	1	PIASTRINA	PLATE	PLAQUETTE	PLÄTTCHEN	PLACA
	5	Z00069056	1	VITE TEF M8x20	FLANGED EXAGON HEAD SCREW M8x20	BOULON DE BRIDE M8x20	FLANSCHENSCHRAUBE M8x20	TORNILLO DE REBORDE M8x20
	6	Y00043928	1	DADO FRENATO M8	SELF-LOCKING NUT M8	ECROU AUTOBLOQUANT M8	SELBSTSICHERNDE MUTTER M8	TUERCA AUTOBLOCANTE M8
	7	8000A1239	3	MOLLA	SPRING	RESSORT	FEDER	MUELLE
	8	F000P01374	1	FLANGIA	FLANGE	BRIDE	FLANSCH	BRIDA
	9	F000P01375	1	BOCCOLA	BUSHING	DOUILLE	BUCHSE	CASQUILLO
	10	F000P01376	1	GUARNIZIONE	GASKET	JOINT	DICHTUNG	JUNTA
	11	Z00069056	2	VITE TEF M8x20	FLANGED EXAGON HEAD SCREW M8x20	BOULON DE BRIDE M8x20	FLANSCHENSCHRAUBE M8x20	TORNILLO DE REBORDE M8x20
	12	F000P01987	1	SONDA LAMBDA	LAMBDA SENSOR	SONDE LAMBDA	LAMBDA-SONDE	SONDA LAMBDA
	13	800056444	2	FASCETTA	CLAMP	COLLIER	SHELLE	ABRAZADERA
	14	60ND02558	2	VITE TCEI M8x35	SCREW TCEI M8x35	VIS TCEI M8x35	SCHRAUBE TCEI M8x35	TORNILLO TCEI M8x35
	15	72040549	1	DISTANZIALE	SPACER	ENTRETOISE	ABSTANDHALTER	DISTANCIADOR
	16	73012323	1	GOMMINO	RUBBER RING	JOINT EN CAOUTCHOUC	GUMMISCHEIBE	GOMA
	17	Y00043928	1	DADO FRENATO M8	SELF-LOCKING NUT M8	ECROU AUTOBLOQUANT M8	SELBSTSICHERNDE MUTTER M8	TUERCA AUTOBLOCANTE M8
	18	U00046893	2	DADO A GRAFFETTA M6	CLIP NUT M6	ECROU À AGRAFE M6	SICHERUNGSMUTTER M6	TUERCA DE CLIP M6
	19	F000P00286	1	PROTEZIONE CALORE	HEAT-PROTECTING COVER	PROTECTION CHALEUR	HITZESCHUTZ	PROTECCIÓN CALOR
	20	F000P03323	1	PROTEZIONE CALORE INF.	LOWER HEAT-PROTECTING	PROTECTION CHALEUR INF.	HITZESCHUTZ UNTEN	PROTECCIÓN CALOR INF.
	21	Z00062725	4	VITE TEF M6x10	FLANGED EXAGON HEAD SCREW M6x10	BOULON DE BRIDE M6x10	FLANSCHENSCHRAUBE M6x10	TORNILLO DE REBORDE M6x10
	22	800035112	4	ROSETTA ISOLANTE	HEAT-PROTECTING WASHER	RONDELLE ANTI-CHALEUR	HITZESCHUTZSCHIEBE	ARANDELA ANTICALOR

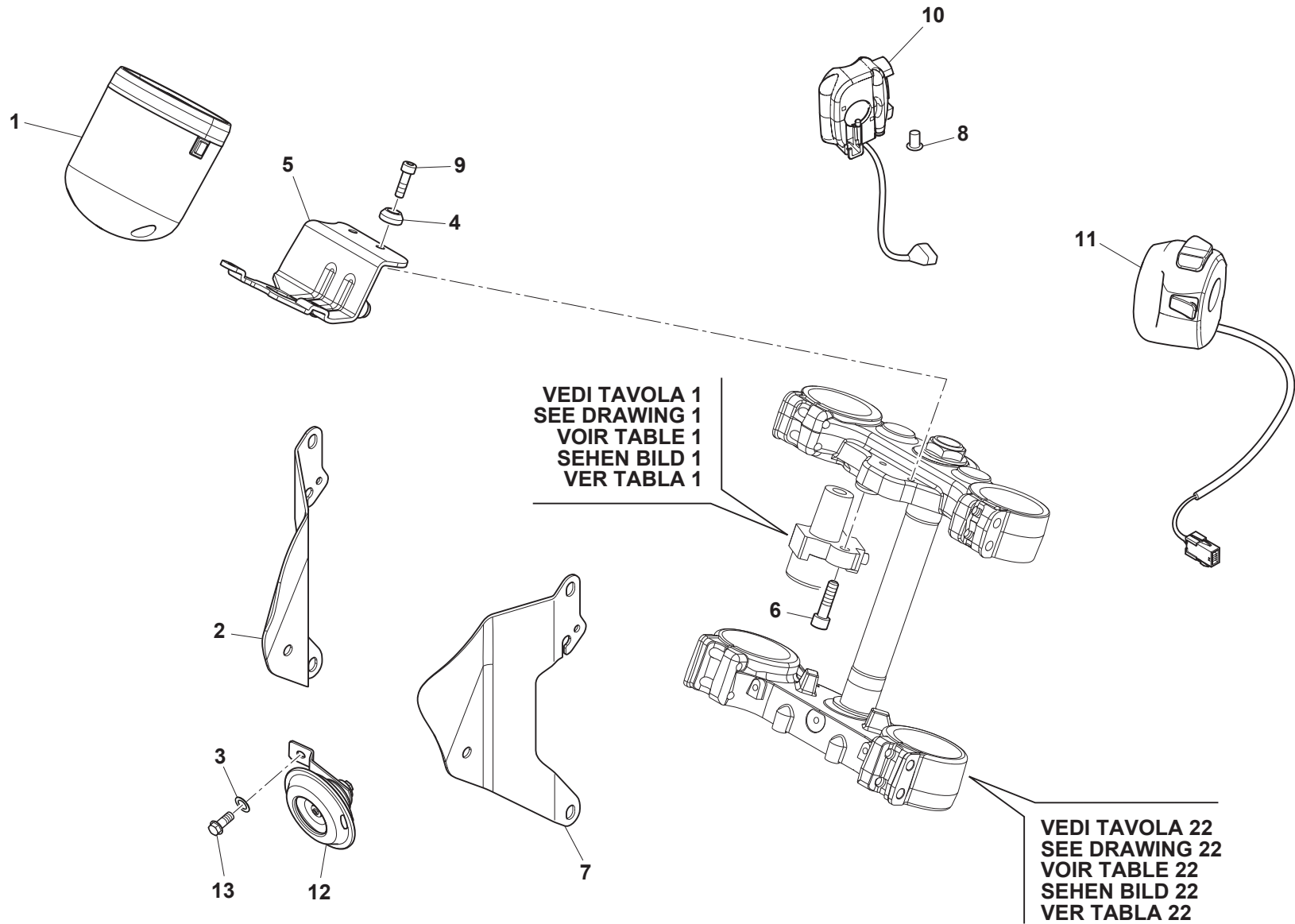



**ACE OF SPADES 125
OUTLAW 125**

**STRUMENTO DIGITALE - DIGITAL INSTRUMENT
INSTRUMENT DIGITAL - DIGITAL TACHOMETER
INSTRUMENTO DIGITAL**

TAVOLA
DRAWING
TABLE
BILD
TABLA

Note Notes Notes Marke Notas	Pos. No. N. Index Pos.	N. Cod. Code No. Nr. Code Code Nr. N. Cod.	Q.tà Q.ty Q.te M.ge C.ad	DENOMINAZIONE	NAME	DESIGNATION	BESHREIBUNG	DENOMINACION
	1	E000P03416	1	ASSIEME STRUMENTO	INSTRUMENT ASSY	INSTRUMENT ENSEMBLE	ZUSAMMENBAU INSTRUMENT	CONJUNTO INSTRUMENTO
	2	F000P03187	1	TELAIETTO DI SOSTEGNO DESTRO	RIGHT HEAD LIGHT FRAME	SOUS-CHASSIS DE SUPPORT DROIT	STÜTZRAHMEN RECHTS	SUBCHASIS DE SUJECION DERECHO
	3	Z00045499	1	ROSETTA	WASHER	RONDELLE	UNTERLEGSCHIBE	ARANDELA
	4	F000P00768	2	RONDELLA CONICA	CONIC SPACER	RONDELLE CONIQUE	UNTERLEGSCHIBE	ARANDELA CONICA
	5	F000P03195	1	STAFFA	BRACKET	ETRIER	BÜGEL	ESTRIBO
	6	60ND02555	2	VITE TCEI M8x20	SCREW TCEI M8x20	VIS TCEI M8x20	SCHRAUBE TCEI M8x20	TORNILLO TCEI M8x20
	7	FA00P03187	1	TELAIETTO DI SOSTEGNO SINISTRO	LEFT HEAD LIGHT FRAME	SOUS-CHASSIS DE SUPPORT GAUCHE	STÜTZRAHMEN LINKS	SUBCHASIS DE SUJECION IZQUIERDO
	8	8000A1074	2	PIOLO IN GOMMA	RUBBER PIN	PLOT EN CAOUTCHOU	GUMMIDÜBEL	CLAVIJA DE GOMA
	9	60ND07335	2	VITE TCEI M6x20	SCREW TCEI M6x20	VIS TCEI M6x20	SCHRAUBE TCEI M6x20	TORNILLO TCEI M6x20
	10	E000P03629	1	COMMUTATORE DESTRO	RIGHT SWITCH	COMMUTATEUR DROITE	UMSCHALTER RECHTS	CONMUTADOR DERECHO
	11	E000P03630	1	COMMUTATORE SINISTRO	LEFT HANDLE SWITCH	COMMUTATEUR GAUCHE	UMSCHALTER LINKS	CONMUTADOR IZQUIERDO
	12	31080131	1	AVVISATORE ACUSTICO	HORN	AVERTISSEUR SONORE	HUPE	AVISADOR ACÚSTICO
	13	ZH0067545	1	VITE TEF M6x12	FLANGED EXAGON HEAD SCREW M6x12	BOULON DE BRIDE M6x12	FLANSCHENSCHRAUBE M6x12	TORNILLO DE REBORDE M6x12

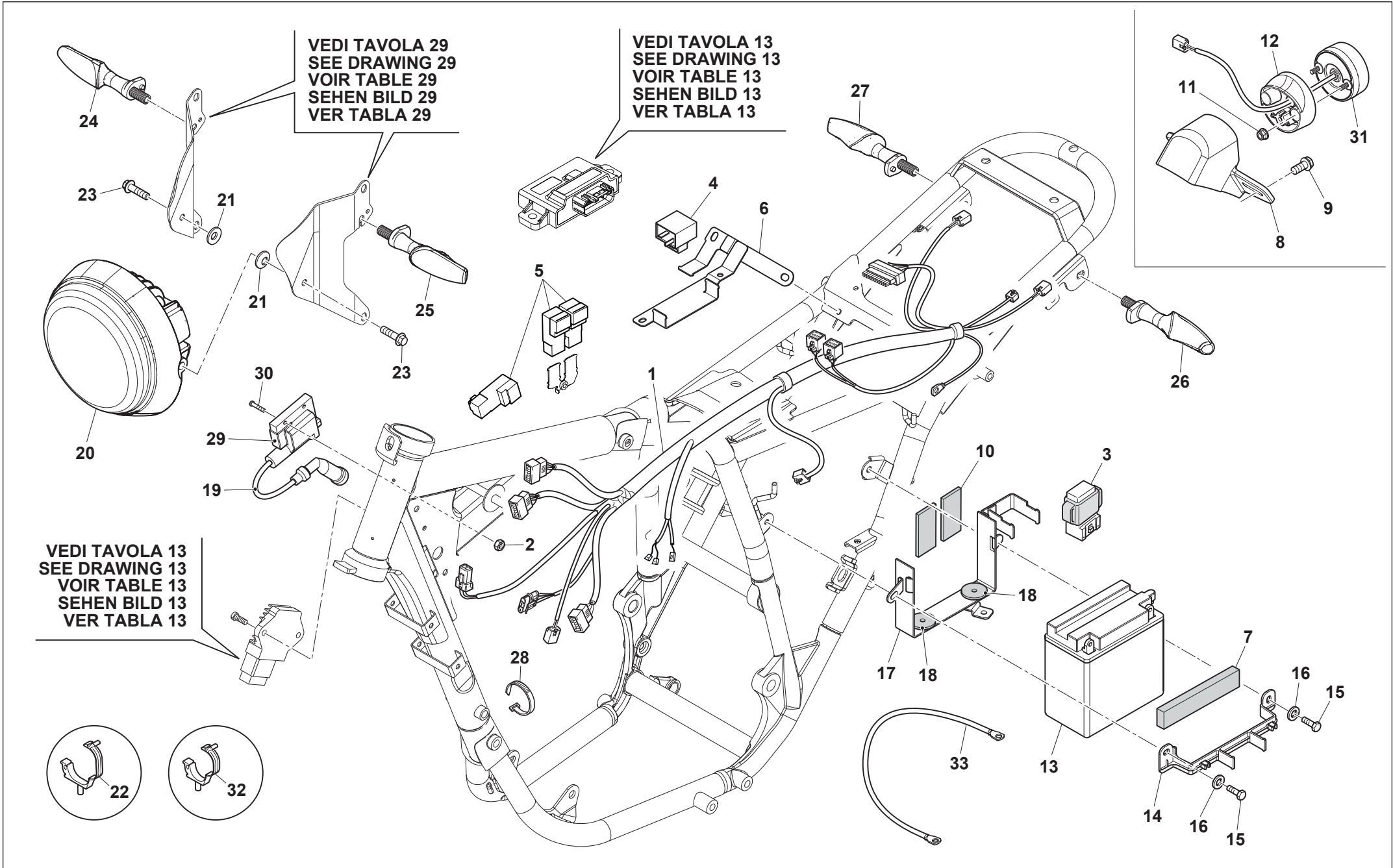



ACE OF SPADES 125 OUTLAW 125

GRUPPO CAVI, PARTI ELETTRICHE - MAIN WIRING HARNESS, ELECTRICAL PARTS CABLES PRINCIPAL, PARTIES ELECTRIQUES - KABEL, ELEKTRISCHE KOMPONENTE GRUPO PRINCIPAL CABLES, PARTES ELECTRICAS

TAVOLA
DRAWING
TABLE
BILD
TABLA

30

Note Notes Notes Marke Notas	Pos. No. N. Index Pos.	N. Cod. Code No. Nr. Code Code Nr N. Cod.	Q.tà Q.ty Q.te M.ge C.ad	DENOMINAZIONE	NAME	DESIGNATION	BESHREIBUNG	DENOMINACION
	1	E000A03500	1	CABLAGGIO PRINCIPALE	MAIN CABLE HARNESS	CÂBLAGE PRINCIPAL	HAUPTVERKABELUNG	CABLEADO PRINCIPAL
	2	Z00040717	2	DADO AUTOBLOCCANTE M4	SELF-LOCKING NUT M4	ECROU AUTOBLOQUANT M4	SELBSTSICHERNDE MUTTER M4	TUERCA AUTOBLOCANTE M4
	3	E000P02437	1	TELERUTTORE AVVIAMENTO	SOLENOID STARTER	SOLENOÏDE DE DEMARRAGE	ANLASSER-FERNRELAIS	TELERRUPTOR ARRANQUE
	4	E000P02280	1	INTERMITTENZA	FLASHER	DISPOSITIF CLIGNOTANTS	BLINKGEBER	INTERMITENCIA
	5	8000A6749	3	RELE POMPA BENZINA	RELAY FUEL PUMP	RELAIS POMPE À CARBURANT	BENZINPUMPE RELAIS	RELÉ BOMBA GASOLINA
	6	F000P00778	1	STAFFA FISSAGGIO ECU	BRACKET	ETRIER	BÜGEL	ESTRIBO
	7	F000P03850	1	SPUGNA	SPONGE	EPONGE	KLEBEGUMMI	GOMAESPUMA
OUTLAW	8	F000P00309	1	PORTATARGA	NUMBER PLATE HOLDER	SUPPORT PLAQUE D'IMM.	NUMMERNSCHILDHALTER	PORTAMATRÍCULA
OUTLAW	9	60ND07330	2	VITE TEF M5x16	FLANGED EXAGON HEAD SCREW M5x16	BOULON DE BRIDE M5x16	FLANSCHENSCHRAUBE M5x16	TORNILLO DE REBORDE M5x16
	10	73012420	2	SPUGNA ADESIVA	SINGLE-SIDED ADHESIVE	ADHÉSIF EPONGE	KLEBEGUMMI	GOMAESPUMA ADESIVA
OUTLAW	11	61ND15192	2	DADO FRENATO	SELF-LOCKING NUT	ECROU AUTOBLOQUANT	SELBSTSICHERNDE MUTTER	TUERCA AUTOBLOCANTE
OUTLAW	12	F000P03182	1	SUPPORTO	SUPPORT	SUPPORT	HALTERUNG	SOPORTE
	13	E000P03274	1	BATTERIA	BATTERY	BATTERIE	BATTERIE	BATERÍA
	14	E000P03275	1	STAFFA FISSAGGIO BATTERIA	BRACKET	ETRIER	BÜGEL	ESTRIBO
	15	Z00062726	3	VITE TEF M6x14	FLANGED EXAGON HEAD SCREW M6x14	BOULON DE BRIDE M6x14	FLANSCHENSCHRAUBE M6x14	TORNILLO DE REBORDE M6x14
	16	Z00021535	2	ROSETTA	WASHER	RONDELLE	UNTERLEGSSCHEIBE	ARANDELA
	17	F000P01643	1	SUPPORTO BATTERIA	BATTERY SUPPORT	SUPPORT BATTERIE	BATTERIE HALTERUNG	SOPORTE BATERÍA
	18	73010197	2	GOMMINO APPOGGIO BATTERIA	DAMPING MAT, BATTERY	JOINT EN CAOUTCHOUC	GUMMISCHEIBE	GOMA
	19	E000P03516	1	CAVO BATTERIA-TELERUTTORE	BATTERY-SOLENOID STARTER CABLE	CÂBLE BATTERIE-TÉLÉRUPTEUR	KABEL BATTERIE-FERNRELAIS	CABLE BATERÍA-TELERRUPTOR
	20	EA00P02570	1	FANALE ANTERIORE COMPLETO	COMPLETE FRONT HEADLAMP	FEU AVANT COMPLET	FRONTSCHIEINWERFER KOMPLETT	FARO DELANTERO COMPLETO
	21	F000P00760	2	RONDELLA CONICA	CONIC SPACER	RONDELLE CONIQUE	UNTERLEGSSCHEIBE	ARANDELA CONICA
	22	8A0060283	1	FASCETTA	CLAMP	COLLIER	SHELLE	ABRAZADERA
	23	60ND02555	2	VITE TEF M8x20	FLANGED EXAGON HEAD SCREW M8x20	BOULON DE BRIDE M8x20	FLANSCHENSCHRAUBE M8x20	TORNILLO DE REBORDE M8x20
	24	EB00P02279	1	INDICATORE ANT. DX	RH FRONT INDICATOR	CLIGNOTANT AV. DROITE	RICHTUNGSANZEIGER VORNE RE	INTERMITENTE DEL. DER.
	25	EC00P02279	1	INDICATORE ANT. SX	LH FRONT INDICATOR	CLIGNOTANT AV. GAUCHE	RICHTUNGSANZEIGER VORNE LI	INTERMITENTE DEL. IZQ.
	26	EE00P02279	1	INDICATORE POST. SX	LH REAR INDICATOR	CLIGNOTANT AR. GAUCHE	RICHTUNGSANZEIGER HINTEN LI	INTERMITENTE TRAS. IZQ.
	27	ED00P02279	1	INDICATORE POST. DX	RH REAR INDICATOR	CLIGNOTANT AR. DROITE	RICHTUNGSANZEIGER HINTEN RE	INTERMITENTE INTERMITENTE DEL. IZQ.
	28	800056444	11	FASCETTA L=188 mm	CLAMP L=188 mm	COLLIER L=188 mm	SHELLE L=188 mm	ABRAZADERA L=188 mm
	29	31020123	1	BOBINA	COIL	BOBINE	ZÜNDSPULE	BOBINA
	30	72030698	2	VITE M4x20	SCREW M4x20	VIS M4x20	SCHRAUBE M4x20	TORNILLO M4x20
	31	F000P02513	1	FANALE POSTERIORE	TAIL LIGHT	FEU ARRIÈRE	HECKSCHIEINWERFER	PILOTO TRASERO
	32	800093101	2	FASCETTA	CLAMP	COLLIER	SHELLE	ABRAZADERA
	33	E000P02243	1	CAVO MASSA	EARTH CABLE	CÂBLE MASSE	MASSEKABEL	CABLE MASA

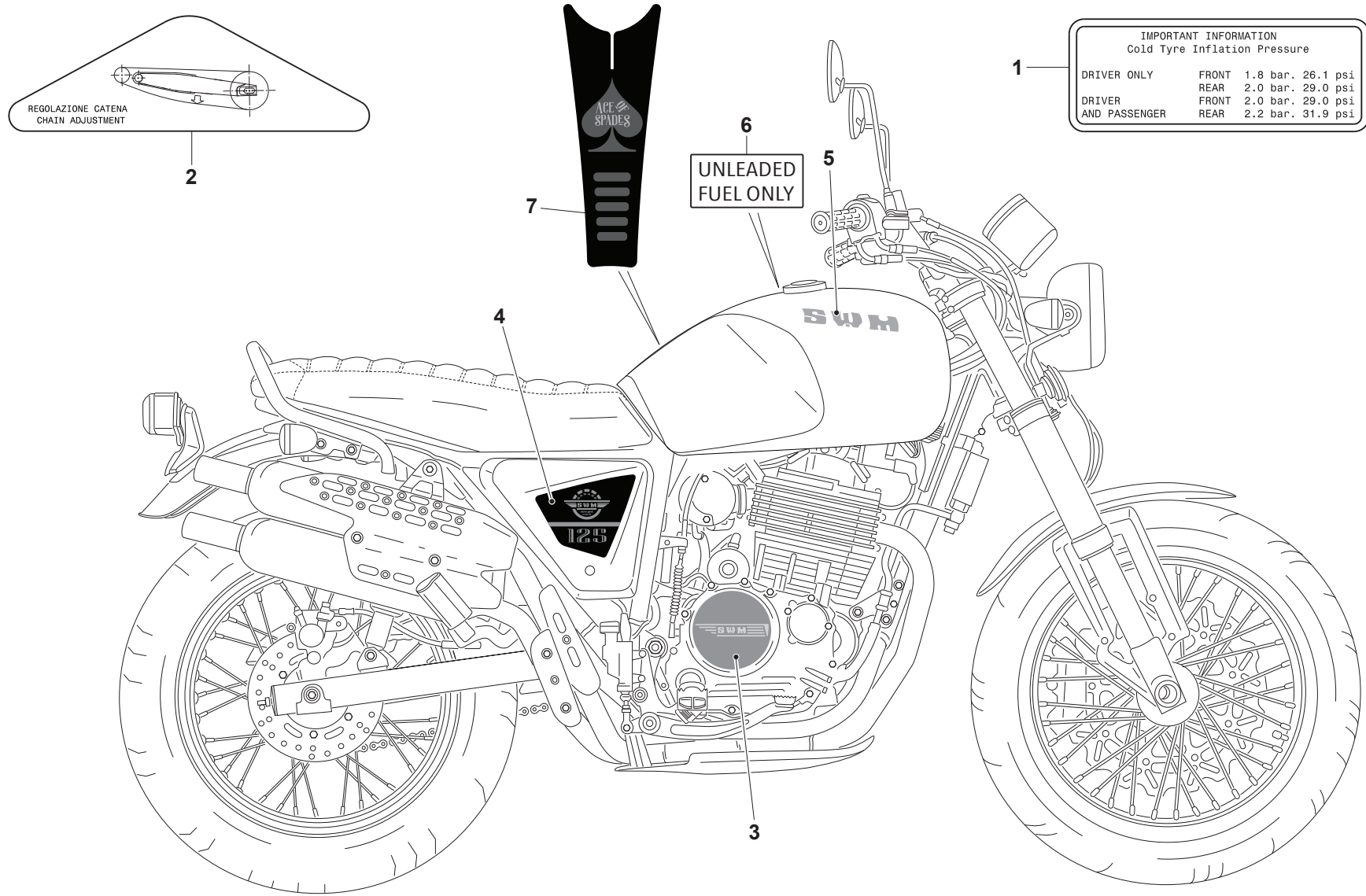

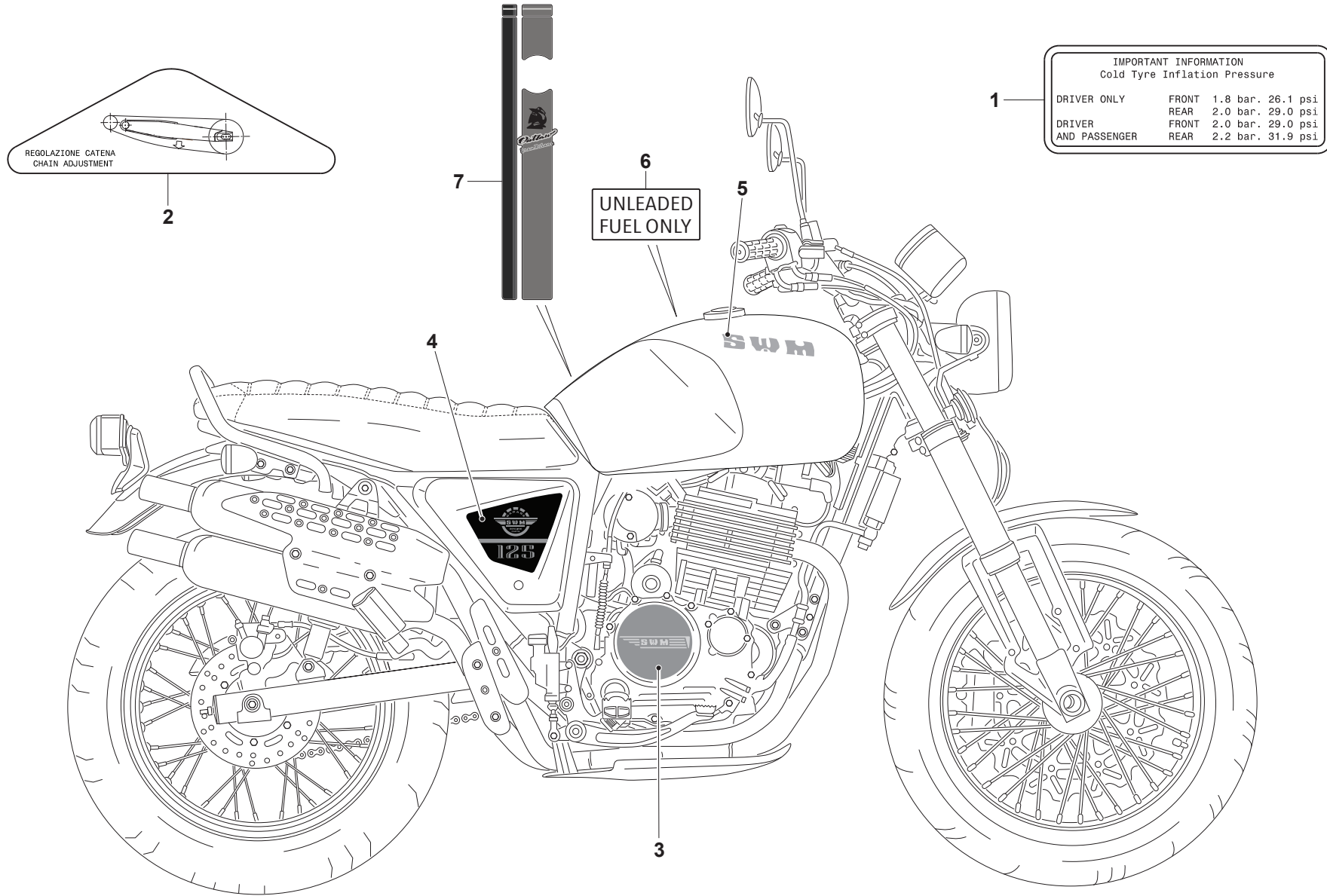

DECALCOMANIE - TRANSFER
DACALCOMANIE - ABZIEHBILD
CALCOMANIA

TAVOLA
DRAWING
TABLE
BILD
TABLA

31A

Note Notes Notas	Pos. No. Index Pos.	N. Cod. Code No. Nr. Code Code Nr N. Cod.	Q.tà Q.ty Q.te M.ge C.ad	DENOMINAZIONE	NAME	DESIGNATION	BESHREIBUNG	DENOMINACION
	1	8B0077871	1	DECALCO PRESSIONE PNEUMATICI	TYRE PRESSURE TRANSFER	AUTOCOLLANT PRESSION PNEUS	AUFKLEBER REIFENDRUCK	CALCOMANÍA PRESIÓN NEUMÁTICOS
	2	A0A0P01093	1	DECALCO REGOLAZIONE CATENA	CHAIN ADJUSTMENT TRANSFER	AUTOCOLLANT RÉGLAGE CHAÎNE	AUFKLEBER KETTENEINSTELLUNG	CALCOMANÍA REGULACIÓN CADENA
	3	M000P01373	1	ADESIVO COPERCHIO FRIZIONE	CLUTCH COVER STICKER	ADHÉSIF COUVERCLE	AUFKLEBERDECKEL	ADHESIVO TAPA EMBRAGUE
	4	F000P03659	1	ADESIVO DESTRO	RIGHT STICKER	ADHÉSIF DROITE	AUFKLEBER RECHTS	ADHESIVO DER.
	4	F000P03660	1	ADESIVO SINISTRO	LEFT STICKER	ADHÉSIF GAUCHE	AUFKLEBER LINKS	ADHESIVO IZQ.
	5	F000P03204	2	ADESIVO SWM	SWM STICKER	ADHÉSIF SWM	AUFKLEBER SWM	ADHESIVO SWM
	6	A000P03858	1	DECALCO BENZINA VERDE	FUEL TRANSFER	AUTOCOLLANT CARBURANT	AUFKLEBER BENZIN	CALCOMANÍA GASOLINA
	7	F0A0P03188	1	ADESIVO SUPERIORE	UPPER STICKER	ADHÉSIF SUPÉRIEUR	AUFKLEBER HÖHERE	ADHESIVO SUPERIOR